

# Handbook for Electric Service

<b>New Hampshire Electric Cooperative Contact Information</b> .....	4
<b>NHEC Office Locations and Towns Served</b> .....	5
<b>New Service Checklist</b> .....	6
<b>Application for Membership &amp; Service</b> .....	7
<b>Load Data &amp; Meter Request Form</b> .....	9
<b>Section 1</b> .....	11
General Information	
<b>Section 2</b> .....	13
Underground Service Installations, Permanent & Temporary	
General Installation Requirements for Underground Facilities	
Secondary	
Primary	
Underground Checklist	
Conduit Trench Inspection Notice	
<b>Section 3</b> .....	18
Overhead Service Installations, Permanent & Temporary	
Basic & Large Basic Service	
<b>Section 4</b> .....	20
Metering	
General	
Services Greater than 400 amp	
<b>Section 5</b> .....	24
Utilization Equipment	
<b>Section 6</b> .....	25
Generating Equipment Owned By Members	
General & Standby Generating Equipment	
Back-up Generator Registration Form	
<b>Section 7</b> .....	29
Specifications	
<b>Section 8</b> .....	60
Glossary of Terms	

# Contact Information

---

## **Member Solutions Department**

**1-800-698-2007**

Application for electric service and requests for information regarding these requirements should be made by calling our Member Solutions Department; this department is open Monday thru Friday from 8:00a.m. to 5:00p.m.

## **Website**

**[www.NHEC.com](http://www.NHEC.com)**

Visit our website for all of the information provided in this Handbook. Our Tariff, Terms and Conditions, Charges and Rates, and Schedule of Fees are also available online as well as referenced in this Handbook.

## **Outage Reporting**

**1-800-343-6432**

There is a fully automated outage reporting system in place, your information can be accessed by phone number or account number. You can now view current outage information on line by visiting our website at [www.nhec.com](http://www.nhec.com).

## **Metering**

**1-800-698-2007**

For Metering questions, please call Member Solutions Department

## **Developments/Subdivisions**

**1-800-698-2007**

Require a unique design, please call Member Solutions Department for assistance

## **Dig Safe**

**1-888-344-7233 or 811**

Always call 72 hours prior to any trenching or excavation work.



# NHEC Operation Centers and Towns Served

ALTON	ANDOVER	COLEBROOK	CONWAY	LISBON
Alton	Alexandria*	Clarksville	Bartlett	Bath
Barnstead	Andover	Colebrook	Conway	Benton
Belmont*	Belmont*	Columbia	Glen	Easton
Epsom	Bristol	Dixville	Hales Location	Haverhill
Farmington	Canterbury	Pittsburgh	Harts Location	Landaff
Gilford*	Danbury	Stewartstown	Intervale	Lisbon
Gilmanton*	Franklin		Jackson	Littleton
Loudon	Gilmanton*			Lyman
New Durham	Grafton*			Monroe
Pittsfield	Hill			Pike
	Northfield			Sugar Hill
	Salisbury			
	Springfield*			
	Sutton			
	Wilmot			

MEREDITH	OSSIPEE	PLYMOUTH	RAYMOND	SUNAPEE
Center Harbor*	Brookfield	Bridgewater	Allenstown	Acworth
Holderness*	Eaton	Campton	Auburn	Charlestown
Laconia	Effingham	Canaan	Brentwood	Claremont
Meredith	Freedom	Center Harbor*	Candia	Cornish
Moultonboro*	Madison	Dorchester	Chester	Croydon
New Hampton*	Moultonboro*	Ellsworth	Danville	Enfield
Sanbornton*	Ossipee	Glenciff	Deerfield	Goshen
Sandwich*	Sandwich*	Grafton*	Derry	Grafton
Tuftsboro*	Tamworth	Groton	Durham	Langdon
	Tuftsboro*	Hanover	Epping	Lempster
	Wakefield	Hebron	Epsom*	Marlow
	Wolfeboro	Holderness*	Fremont	Meriden
		Lincoln	Kingston	Newport
		Lyme	Lee	Plainfield
		New Hampton*	Londonderry	Springfield*
		Orange	Northwood	Sunapee
		Orford	Nottingham	Unity
		Piermont	Raymond	Washington
		Plymouth	Sandown	
		Rumney		
		Sandwich*		
		Thornton		
		Warren		
		Waterville		
		Wentworth		
		Woodstock		

\*These towns served by multiple Operation Centers

# New Service Checklist

---

In order to improve our efficiency, we ask that you review the information in this handbook thoroughly. Please review the following checklist to ensure that you have completed all applicable steps before calling us for your service connection.

Please be advised that in order for New Hampshire Electric Cooperative (hereinafter referred to as NHEC) to connect service, installations must meet NHEC specifications. If NHEC specifications are not met, applicable charges, per NHEC's Tariff will apply.

- Is a foundation in place?
- Has an application been submitted? *(see page 5 of this handbook)*
- Has the service entrance size been determined?
- Has a Load Data Survey Sheet been provided for all three-phase services and any single-phase service over 400 amp? *(see page 7 of this handbook)*
- Has the choice of overhead or underground service been determined?
- Do you know the date service is needed?
- If applicable has the location for the temporary service been determined?  
*(Subject to NHEC's approval)*
- Have you determined the location for the permanent service?  
*(Subject to NHEC's approval)*
- Has easement information been provided (book and page # of deed, tax map and lot #, bordering lot ownership with applicable tax map and lot #'s) signed in black ink and notarized. If this is a parcel with a subdivision you must include the subdivision name on the easement.
- Has a municipal inspection been received?
- Have you made all necessary prepayments?

**APPLICATION FOR MEMBERSHIP & SERVICE**  
**NEW HAMPSHIRE ELECTRIC COOPERATIVE, INC**  
 579 TENNEY MOUNTAIN HIGHWAY – PLYMOUTH, NEW HAMPSHIRE 03264  
 (800) 698-2007

Revised 2/04

<b>Service Order Number:</b>	<b>Pole Number:</b>	<b>Meter Number:</b>
------------------------------	---------------------	----------------------

Name: (Print): \_\_\_\_\_  
First Name
Middle Name
Last Name

Other Applicants: \_\_\_\_\_  
 (Use back if necessary) First Name
Middle Name
Last Name

Permanent Mailing Address: \_\_\_\_\_

Phone Number: Home \_\_\_\_\_ Business \_\_\_\_\_

Address of Service: \_\_\_\_\_

Where service is to be rendered:

Residence \_\_\_\_\_ Business \_\_\_\_\_ Other \_\_\_\_\_

Property Owned \_\_\_\_\_ Rented \_\_\_\_\_

Owner's Name & Phone Number \_\_\_\_\_

Anticipated period of occupancy \_\_\_\_\_

Date electric service became your responsibility \_\_\_\_\_

Have you previously been served by the Cooperative? \_\_\_\_\_

If so, in what town? \_\_\_\_\_ When terminated? \_\_\_\_\_

KIND OF SERVICE DESIRED: (Check applicable service) Will service be underground? Circle one: Yes No  
 SINGLE-PHASE SERVICE: \_\_\_\_\_ MAIN PANEL SIZE = \_\_\_\_\_ AMPS \_\_\_\_\_  
 THREE-PHASE SERVICE: \_\_\_\_\_ MAIN PANEL SIZE = \_\_\_\_\_ AMPS \_\_\_\_\_  
 THREE-PHASE SERVICE: (Commercial) \_\_\_\_\_ REQUIRED VOLTAGE **(Check one)** 120/208 \_\_\_\_\_ 277/480 \_\_\_\_\_  
 OUTDOOR LIGHTING: \_\_\_\_\_

Is there an electric water heater in use here? \_\_\_\_\_

Is there permanently installed electric space heating in use here? \_\_\_\_\_

I/We hereby apply for membership in the New Hampshire Electric Cooperative, Inc., and for electric service to be supplied at the address herein described. I/We agree to pay for the service therefore subject to Rates, Terms, and Conditions of the New Hampshire Electric Cooperative, Inc., as filed with the Public Utilities Commission and in effect at the time of delivery or as subsequently revised. I/We have noted the minimum term of service specified in the applicable rate and understand that should service be requested to be terminated within such minimum term of service that I/We shall pay such amounts required to fulfill the minimum term of service requirements. I/We further understand that should the service herein requested involve a so-called line extension as defined within the terms and conditions of the tariff of the New Hampshire Electric Cooperative, Inc., that I/We shall enter into a contract for the required minimums for the required period with the New Hampshire Electric Cooperative, Inc., such contract to be of such a form as normally used by the Cooperative. I/We shall reimburse the Cooperative for all fees associated with the recording of necessary easements. **In signing this application, I/We hereby agree to the extending and maintenance of utilities within the boundaries of my/our property. I/We recognize that the Cooperative has a right to construct, repair, operate, maintain, patrol, replace and remove overhead and underground lines consisting of wires, ducts, cables, poles, and other apparatus necessary for the transmission and distribution of electricity over and under my/our land in New Hampshire. This includes any necessary cutting and trimming of vegetation 15 feet on either side of the electric lines. Planting of trees, building of structures or storage of lumber and/or other materials within this right-of-way shall not be undertaken without the knowledge and consent of the Cooperative. I/We will not hinder or obstruct the installation or reliability of services to other members of the Cooperative. As a member of the Cooperative I/We agree to be bound by its Charter and Bylaws.**

Social Security No. \_\_\_\_\_  
 (Required)

Signed \_\_\_\_\_

Social Security No. \_\_\_\_\_  
 (Required)

Signed \_\_\_\_\_

Deposit Required \$ \_\_\_\_\_

Date \_\_\_\_\_



**NEW HAMPSHIRE ELECTRIC COOPERATIVE, INC.**  
**LOAD DATA AND METER REQUEST FORM**



**Please Submit for all 3 Phase Services and any Single Phase Service ≥ 400 Amps**

MEMBER / CO. NAME:	MEMBER PHONE #:
MEMBER ADDRESS:	MEMBER CONTACT PERSON:
SERVICE ADDRESS:	
CONTRACTOR NAME:	CONTRACTOR PHONE#:
CONTRACTOR CONTACT PERSON:	CONTRACTOR CONTACT PHONE #
ELECTRICAL CONTRACTOR NAME:	ELECTRICAL CONTRACTOR PHONE #
ELECTRICAL CONTACT PERSON:	ELECTRICAL CONTACT PHONE #

SERVICE EQUIPMENT DATA		
MAIN PANEL SIZE: _____	MAIN BREAKER SIZE: _____	
Please Circle <b>SINGLE PHASE: 120/240v</b> <b>Three Phase 4 WIRE: 120/208v or 277/480v</b> <b>Delta: 3wire or 4wire</b>		

ELECTRICAL CONNECTED LOADS MUST BE REFLECTED IN KW			
LIGHTING:	WASHER:	GEO THERMAL	YES OR NO
RECEPTACLES:	DRYER:	GEO THERMAL LARGEST MOTOR SIZE	
SPACE HEATING:	ELEVATOR:		
WATER HEATING:	MISCELLANEOUS:		
AIR CONDITIONING:	OTHER "DESCRIBE":		
MOTORS:	EMERGENCY GENERATION?	KW:	
<b>ESTIMATED DEMAND = TOTALED CONNECTED LOAD IN KW _____ X 0.8 = _____</b>			

LARGE ELECTRICAL EQUIPMENT AND MOTORS	1 or 3 PHASE	VOLTS	HORSE POWER	RENEWABLE ENERGY DATA AND INSTALLING CONTRACTOR INFORMATION
				RENEWABLE SOURCE PV, WIND, HYDRO
				INSTALLERS NAME:
				INSTALLERS PHONE#
				INVERTER SIZE(kw):
				GROUP NET HOST PROJECT? YES OR NO
				GROUP NET HOST# OF MEMBERS _____

**Form filled out by:** \_\_\_\_\_ **Title:** \_\_\_\_\_  
 I certify that the information provided above on this form is accurate, and it correctly reflects the expected electrical load.

**Signature:** *X* \_\_\_\_\_ **Date:** \_\_\_\_\_

**Section to be completed by Line Design Tech:** \_\_\_\_\_ **Note: Shaded Section area for Internal Use Only**

<b>WO #</b>	<b>District:</b>	<b>Pole #</b>	<b>Date:</b>
<b>Member Account Number:</b>		<b>Designer:</b>	
<input type="checkbox"/> 3 Ph Self Contained	<input type="checkbox"/> 1 Ph XFMR Rated ≥ 400A	<input type="checkbox"/> 3 Ph XFMR Rated ≥ 400A	
<b>Meter Socket Mounting:</b>	<input type="checkbox"/> Building	<input type="checkbox"/> XFMR	<input type="checkbox"/> Pole <input type="checkbox"/> Other: _____
<b>CT Metering Method:</b>	<input type="checkbox"/> Primary	<input type="checkbox"/> Secondary	
<b>CT Mounting:</b>	<input type="checkbox"/> Pole Mount	<input type="checkbox"/> Pad Mount	<input type="checkbox"/> CT Enclosure <input type="checkbox"/> Other: _____
<b>Meter Dept Section:</b>	<b>Installer:</b>	<b>Co-op #</b>	<b>Ratio</b>
<b>Meter Prog #</b>	<b>Meter #</b>	CT	VT
<b>Date Complete:</b>		CT	VT
<b>XFMR Loss Compensation Y / N</b>		CT	VT

Reply To: New Hampshire Electric Cooperative, Inc 579 Tenney Mtn. Highway, Plymouth, NH 03264 (800) 698-2007

Revision 1.0





# Section 1: General Information

---

This handbook should be used only as an aid to help Members and others better understand the services available from NHEC; it has been prepared to assist you in planning your service installations. It is impractical to attempt to cover in a booklet of this type all of NHEC's approved Specifications or all of the conditions and problems which may be encountered in various installations. It is very important that these instructions and standards are adhered to in every detail. This will prevent delays and possible additional costs to you. It is the Member's responsibility to ensure that all wiring, materials and installations comply with the most recent issue of the National Electrical Code (hereinafter referred to as NEC) and any other federal, state, or local codes that apply. Where conflict(s) exists the more stringent code will apply. Readers are encouraged to refer to the actual text of NHEC's Bylaws, NHEC's Terms and Conditions, NHEC's Tariffs, or any relevant contract.

- The installation of a new service is a joint effort between the Member, the Contractor, and NHEC. This handbook is provided to help you become aware of our policies and practices. This should ensure a timely and cost-effective installation.
- New Hampshire Electric Cooperative strives to render dependable electric service in accordance with the Tariff for Delivery Service which can found on our website.
- Before proceeding with the wiring of a new building or the rewiring of an existing building, a service entrance location shall be arranged by calling NHEC Member Solutions Department to generate a service order.
- For single phase service, four conductors must be installed from the meter main to the distribution panel, for new construction, service upgrades, renovations and relocations.
- Whether or not a signed application for service is made by the Member and accepted by NHEC, the rendering of the service by NHEC and its use by the Member shall be deemed a contract between the parties and subject to provisions of the Tariff. NHEC reserves the right to reject any application for service made by, or for the benefit of a former Member who is indebted to NHEC for delivery of electric service previously furnished to them.
- NHEC reserves the right to reject any application for service if the amount or nature of the service, or the distance of the premises to be served from an existing suitable line, or the difficulty of access thereto is such that the estimated income from the service applied for is insufficient to yield a reasonable return to NHEC, unless such application is accompanied by cash payment.
- The applicant for service will provide, without expense or cost to NHEC, the necessary permits, consents, or easements for a satisfactory right of way for the erection, maintenance and operation of a line, including the right to cut and trim trees and bushes wherever necessary along private property.
- Access shall be safe and adequately maintained to NHEC owned equipment located on a Member's property. NHEC reserves the right to enter the premises to install, maintain, repair, and disconnect meters, equipment, facilities and for all other proper purposes. If safe and adequate access to the meter/equipment is not available for NHEC employees, we reserve the right to discontinue service upon proper notice.
- All NHEC employees are required to carry means of identification which will be shown upon request.

- Should the use or operation of any equipment by a Member including but not limited to electric motors, welders, electronic power supplies or speed controls, adversely affect NHEC’s ability to render adequate service to others, NHEC reserves the right to discontinue service until suitable corrections are made by the Member.
- For the cost to relocate a meter please reference **Schedule of Fees, Charges and Rates** located on NHEC’s website.
- Meter sockets may be temporarily removed (floated) from buildings by NHEC personnel at the Member’s request for siding and cosmetic repairs. This is to be considered temporary in nature and provisions for re-attachment must be made by the Member within one year. Please reference **Schedule of Fees, Charges and Rates**, under Modifications of Existing Services located on NHEC website.
- NHEC meters, poles, anchors, vaults and other equipment are to be within 15 feet of a traveled way or driveway, considered to be truck accessible year round.
- Subdivisions/Developments require a unique design, please contact NHEC for assistance.
- Available Service Voltages:

PHASE	WIRES	NOMINAL VOLTAGE
Single	3	120/240
Three	4	120/208
Three	4	277/480

## **ATTENTION ELECTRICIANS!**

### **Don’t pull that meter until you’ve notified us...**

Electricians: you must contact New Hampshire Electric Co-op BEFORE breaking the seal to remove any electric meter that is served by NHEC.

This is especially important as NHEC transitions to an automated outage reporting system. The new digital electric meters installed by NHEC during the past two years will automatically report an outage when the meter loses power. If we don’t know you’re removing a meter, we may assume there’s an outage at that location or that the meter is being tampered with and dispatch a crew to make repairs. That may result in the member being billed a charge.

According to NHEC’s Terms & Conditions, only licensed electricians and trained NHEC employees are allowed to remove an electric meter from its socket.

Before removing an NHEC electric meter, please call 1-800-698-2007 to reach our Member Solutions Department during regular business hours, or our Control Center, which is staffed 24/7/365.

# Section 2: Underground

---

## GENERAL INSTALLATION REQUIREMENTS FOR UNDERGROUND FACILITIES

- Underground electric service and meter location will be established by NHEC upon site visit.
- In some instances the type, nature, and/or size of the service requested by a Member may not be available at a desired location.
- When **temporary underground service** is required, the installation shall be in accordance with Construction Standard UTS 1, located in the back of the book. The process and costs of obtaining temporary underground service varies, depending upon the location of existing facilities. After contacting NHEC and meeting a Line Design Technician in the field, the Member then installs the temporary service equipment and structure, has it inspected (when required by the town), and then calls NHEC. Service will be connected once the required documentation, prepayments, and permits have been completed. "Temporary" is installed to provide power during the construction phase of a project and is defined as less than one year by the Federal Energy Regulatory Commission. To continue service beyond one year, the service must be converted to a permanent service and meet all pertinent requirements of this handbook.
- For conductor requirements:
  - Single phase service 400 amps or less, NHEC provides conductors to the line side of the meter socket.
  - Single phase service 800 amps or less for multi-gang meter socket requires parallel runs, NHEC provides conductors to the line side of the meter socket.
  - Single phase service greater than 400 amps, Member provides all underground service conductors.
  - Three phase service Member provides all underground service conductors.
- In the case of underground facilities, a Member shall not erect or maintain any building, structure, or any part of the septic system over such facilities, and shall not plant any trees or shrubs over such facilities, and shall not substantially change the grade over or adjacent to such facilities.
- NHEC vaults and other equipment are to be within 15' of a traveled way or driveway, considered to be truck accessible year round.
- Minimum Clearances from equipment see Specification SP-2, located in the back of the book. The Member must contact NHEC to determine appropriate clearances. These clearances shall not supersede any local ordinance or code which requires greater clearance. If additional fire protection is necessary for insurance and/or other purposes, it is the responsibility of the building/property owner and/or Member to provide additional protection.
- The Member shall furnish at their expense and adhere to NHEC specifications all trenching, backfilling, manholes, conduits, ground wire and vaults necessary for the installation of underground electric distribution facilities.
  - Red Caution Ribbon shall be furnished and installed by the Member. This shall be installed the entire length of the trench above the conduit, a foot below finished grade.
  - A pulling rope, 1/4 inch diameter polypropylene, shall be installed in each conduit.

- Trenches shall be as straight as possible with no more than 180° of bends which will consist of no more than two 90° sweeps where the run transitions from underground to above ground. Routes through unstable soil such as mud, shifting soils, or other hazards should be avoided.
- Any significant change in the direction of the run shall be accomplished by use of an appropriate pull box.
- Underground facilities shall be a minimum of schedule 40 PVC and maintain a minimum depth of 36 inches to finish grade.

**EXCEPTIONS:**

- Conduits emerging from grade, above grade, under travel ways, roads and driveways, Schedule 80 PVC shall be used.
- Conduits installed less than 36 inches in depth require NHEC approval after site review and shall be encased in concrete to NHEC's specs.
- Any conduits crossing or within 6 feet of drainage, water, gas, septic or sewer lines, must be encased in concrete.
- Underground conduit systems shall not be installed within 15 feet of any building foundation, swimming pool, etc., except for where service conduit merges to intercept the service equipment.
- The ends of the conduit shall be plugged during construction to prevent the entrance of foreign matter. The conduit shall be terminated as follows:
  - Conduit shall terminate not more than 3 inches inside a vault. Whenever possible the conduit should run straight into the vault without sweeps or bends. Where the conduit enters the vault, it shall be sealed with hydraulic cement to prevent water, soil and rock intrusion.
- All ends, joints and internal finish of the conduit shall be free of sharp edges or burrs which could damage the cable.
- All conduit joints shall be glued as recommended by the conduit manufacturer. Colored PVC cleaner shall be used before applying glue.
- The Member shall be responsible for having the conduit/vault system ready, prior to NHEC personnel installing the cable. Any additional changes, repairs or other work required to the underground conduit/ vault system in order for NHEC personnel to pull the cable into the conduit shall be the responsibility of the Member.
- Member shall be responsible to cover all open holes or trenches to mitigate any hazardous conditions at the job site prior to NHEC starting their work.

**SECONDARY**

- Sweeps: Electrical grade schedule 40 PVC 90° sweep(s) with a minimum radius of 36 inches may be suitable in straight runs between riser pole and meter locations less than 200 feet for 3 inch PVC and 150 feet for 4 inch PVC. If runs exceed these limits, then all 90° sweeps must be galvanized steel.
- If a reduction in the service conduit is required, it will occur at the top of the slip joint/expansion fitting utilizing a reducing bushing. The slip joint/expansion fitting will remain the same size as the conduit installed in the trench with the transition occurring above ground. Refer to Construction Standard IU Service Reduction located in the back of the book.

- Secondary trenches: Required 6 inch minimum spacing between all conduits and trench sidewalls. Refer to Construction Standard IU Secondary Trench, located in the back of the book.
- Conduits installed in pedestals must be straight up and in close proximity in order to make proper connections.
- At meter locations, the conduit shall terminate as per appropriate meter installation specs. If the meter socket is at a lower grade than the pad mounted equipment location or part of the underground conduit system, provisions shall be made as necessary so that the conduit will not fill with water and run into the meter socket. If a slip coupling (with O-rings removed) is utilized, a six inch deep, one foot wide, and two foot long stone base will be set up under the slip joint for drainage.

## **PRIMARY**

- Sweeps: Electrical grade steel 90° sweep(s) with a minimum radius of 36 inches shall be required where the run transitions from underground to above ground. Sweep shall not be used in the underground portion of the primary run.
- Primary trenches: Require 6 inch minimum spacing between all electric conduits and requires a continuous #6 bare AWG copper grounding conductor that shall be directly buried in the bottom of the trench, prior to installation of any conduit, with a 20 foot coil at each end for connections by NHEC. Refer to Construction Standard IU Primary Trench located in the back of the book.
- Joint trenches: When electric facilities are installed jointly with communication facilities, clearance between conduits have to maintain 12 inch, the #6 AWG copper bonding conductor, should be readily accessible with adequate length at both ends and shall be installed at each vault and pad mounted equipment location between electric and communication facilities. Refer to Construction Standard IU Primary Trench, located in the back of the book.
- A drainage system must be installed to daylight in all vaults and sub surface structures. In areas of high water table, vaults and conduit may need to be elevated to promote effective drainage. If the first vault from the riser pole is at a higher grade than the riser location, provisions shall be made as necessary so that the conduit will not fill with water and run up into the riser. If a slip coupling (with O-rings removed) is utilized, a six inch deep, one foot wide, and two foot long stone base will be set up under the slip joint for drainage.
- The maximum length between vaults is no more than 600' without Engineering approval.
- Primary splices must be made in vaults.
- All vaults have to be parallel with the travel way.
- All primary conduits entering vaults must use the pre-casted knockouts located on the long end of the vault.
- Loop feeds are required when two or more underground transformers are installed. Refer to Construction Standard URD 1B, located in the back of the book.

# Underground Checklist

---

In order to improve our efficiency, we ask that you review the entire Section 2: Underground; of this handbook in order to ensure a timely and correct underground installation. Please be advised, NHEC can best serve you providing that you give us as much notice in advance as possible. If NHEC specifications are not met, applicable charges, per NHEC's Tariff will apply. Please call our Member Solutions Department at (800) 698-2007 and reference your Work Order # \_\_\_\_\_

Please be sure to that you have completed all applicable steps below:

- Did you contact NHEC for a trench inspection?
- Is your trench the proper depth?
- Did you install the correct conduit meeting NHEC minimal requirements?
- Did you use the correct minimal radius 36" sweeps? (Steel or PVC)
- Did you use the proper amount of sand in the trench?
- Did you install the Copper Ground Conductor (if applicable)?
- Did you install the correct Caution Ribbon at the right depth?
- Did you install the correct Pulling Rope?
- Is the meter located in the NHEC pre-determined location?

# Conduit and Trench Inspection Notice

---

All contractors and developers requesting underground inspections shall call the Member Solutions Department at 1-800-698-2007 a minimum of 2 business days before the trench is started to make arrangements for an on-site inspection by NHEC Construction personnel. NHEC will conduct an on-site inspection within 2 business days of the inspection request.

At the time of inspection NHEC will verify the following:

- Proper trench depth and location
- Conduit Schedule
- Installation of copper wire as required
- Conduit properly bedded in sand or select backfill

**Refer to Section 2:** *“Underground Service Installations, Permanent & Temporary”*

Once certification has been completed, an NHEC “approval” sticker will be placed on the conduit in order to notify all parties that the underground electrical system has been inspected and approved.

Failure to comply with this requirement will result in the system being re-exposed so that the proper inspection can be performed. No electrical service will be installed until the inspection sticker is in place.

Please be prepared to give all information regarding your project to our Member Solutions representative, including your Service Order #

\_\_\_\_\_.



**CONTACT NUMBER:  
1-800-698-2007**

# Section 3: Overhead Service Installation

---

## BASIC & LARGE BASIC SERVICE

- All entrance wiring must be completed before NHEC extends service drop conductors to the building.
- Only one service of the same characteristics will be run to a single building except as otherwise permitted by the NEC, or local authority having jurisdiction.
- The point of attachment of a service to a Member's building shall not be less than 15 feet, and no more than 20 feet above permanent ground level. The ground shall be reasonably level to permit the use of a ladder by NHEC employees to attach the service. Service attachments shall be so installed as to permit the service connections to be directly reached from a ladder placed securely on the ground, and as to permit the maintenance of the following minimum clearances as per the National Electrical Code. Refer to Specification SP-3, located in the back of the book
  - Point of attachment must be located 3 feet from a window.
  - Twelve feet above finished grade, sidewalks, residential driveways, and commercial areas not subject to truck traffic.
  - Sixteen feet above roads, streets, alleys, residential driveways, cultivated fields, and areas subject to truck traffic.
  - State Roads require 18 feet clearance.
- The maximum length of service drop which NHEC will install is determined by the characteristics of the load to be served and the terrain over which the service drop passes. If necessary to maintain minimum clearances, additional pole(s) will be installed by NHEC on the Members property.
- Where a building is too low to provide minimum clearance, the Member shall install a service mast of suitable height and strength, guyed if deemed necessary. When such a service mast is installed, the Member shall assume full responsibility for the installation, including roof leaks and shall have adequate strength to support the required service drop. Per NEC requirements, only power service drop conductors may be attached to such mast. Refer to Specification SE-4, located in the back of the book.
- When **temporary service** is required, the installation shall be in accordance with Construction Standard TS 1, located in the back of the book (alternative supporting structures may be used as approved by NHEC). The process and costs of obtaining temporary Overhead service varies, depending upon the location of existing facilities. After contacting NHEC and meeting a Line Design Technician in the field, the Member installs the temporary service equipment and structure, has it inspected (when required by the town), and calls NHEC. Service will be connected once the required documentation, prepayments, and permits have been completed. "Temporary" is installed to provide power during the construction phase of a project and is defined as less than one year by the Federal Energy Regulatory Commission. To continue service beyond one year, the service must be converted to a permanent service and meet all pertinent requirements of this handbook.



- For all overhead service entrances, NHEC will furnish and install the service drop to the point of attachment located on the building or other location, and connectors to connect the service drop to the Member's service entrance conductors. The Member shall furnish and install all necessary service entrance equipment beyond the service drop attachment. For a pole mounted entrance the Member is to furnish materials above meter socket and NHEC will install.
- Where it is considered necessary by the NHEC for the proper installation of large capacity overhead services conductors, the Member shall supply a suitable attachment in the building's exterior wall to support the service drop(s).
- For services to semi-permanent mobile homes, the Member shall install the meter socket with integral main breaker on a suitable service entrance structure separated from the mobile home. Refer to Construction Standards SE 2, SE 3 and USE4 located in the back of the book.

# Section 4: Metering

---

## GENERAL

A Load Data Sheet is required for all three phase services and any single phase service greater than or equal to 400 amps.

NHEC may refuse to connect a service or install a meter on any metering installation that does not conform to NHEC's "Requirements for Electric Service Connections".

Meter sockets will be provided by Member.

Meters will be furnished, owned, and maintained by NHEC and shall be installed, removed, and changed only by authorized NHEC employees.

**NHEC does not allow Master Metering;** See NHEC Terms & Conditions.

## REMOVING AND INSTALLING METERS

Only qualified personnel authorized by NHEC (Meter and/or Operations department), are permitted to cut seals, and remove or install meters. Under emergency conditions, exceptions may be granted to qualified electricians by contacting NHEC. When this occurs the party accepts all liability for damage or alteration to equipment, injury to persons or property, and loss of revenue to NHEC from the time the seal is removed until 72 hours after NHEC has been notified that the equipment is ready to be re-sealed. The Member or electrical contractor must promptly notify NHEC when repairs or modifications have been completed. Extreme caution must be used when meters are removed or installed. Depending upon the type of service or meter base, removal of the meter might not de-energize the service.

## METER LOCATION

The Member must install the meter socket where it will be accessible to NHEC personnel. Meter socket locations require prior approval by a representative of NHEC. The Member must provide a location to install metering equipment. The meter location must be free from obstruction, corrosive atmosphere, abnormal temperature, vibration, and be convenient to NHEC distribution system. All meters, meter equipment, and enclosures must be readily accessible by NHEC's personnel during normal business hours for meter reading, maintenance, testing, installation, or removal.

### **The acceptable locations for meter socket are:**

- Located outside, except for a pre-approved electrical room.
- Located on the front one-third of the house closest to normal public access and/or NHEC's service point.
- Located on the driveway gable side.
- Located in an area that is not subject to being fenced.
- Located on a structure that is owned by the Member.

### **The unacceptable locations for meter socket are:**

- Above the first story level or below the first basement level of a building. Any exceptions to this rule must have the approval of NHEC's Meter Department before electrical installation begins.
- On poles not owned by NHEC.
- On any line pole occupied solely by the telephone company, except to serve telephone company equipment.
- In commercial occupancies they do not serve.
- Any place where safety may be compromised.
- Located under an eave with less than a 12 inch overhang, meter will require a shelter over it to prevent ice damage.
- On pad mount transformers.

**The reasons for these requirements are:**

- If there is a fire or other disaster, NHEC can disconnect service.
- So NHEC can read the meters in a safe, cost effective manner.
- So NHEC can efficiently maintain the meter.
- So NHEC employees can stay out of the Member's backyard.

**METER SOCKET REQUIREMENTS**

- Require NHEC approval (see approved listing at [www.nhec.com](http://www.nhec.com))
- Meter socket must have an integral main breaker for services of 400 amp or less.
- Any Commercial or three-phase installations, 400 amps or less, require a meter socket with an integral main breaker and a lever by-pass.
- Be rated for exterior use, and be rain tight according to NEMA-3R
- Be UL (Underwriters Laboratory) approved for application.
- Have all unused openings tightly sealed from the inside of the socket
- Be plumb and securely fastened to the supporting structure.
- The meter socket may be ring or ringless type.
- Meter sockets shall not be altered or bypassed to provide power.
- Any meter socket containing energized equipment must be covered and sealed with a transparent cover plate when a meter is not installed.
- Terminals must be clearly marked with a Manufacturers listing and labeling for the intended use.

**METER SOCKET LABELING**

Multiple meter sockets shall be permanently labeled to indicate the section or unit they serve. The label shall be placed directly adjacent to the service switch or circuit breaker for the identified unit. Labels shall not be mounted on removable covers. The Member's name is not acceptable. The labels must be engraved phenolic identifying plates, fade resistant and at least one inch high. Felt-tip pens and label maker tape are not considered permanent markings. Service will not be established until marking is complete and verified for accuracy. For multi-metered unit locations each meter socket shall be marked with the appropriate unit number and verified by the installation electrician.

**FACTORY BUILT MULTIPLE METER PANEL**

Prior to shipment from the factory, the manufacturer must submit commercial multiple meter panel drawings to the NHEC Meter Department for approval.

**SERVICE CONDUCTORS**

Metered circuits must not enter raceways or enclosures containing unmetered circuits, except for meter loops on poles, or in specific situations approved by NHEC Meter Department. Enclosures and raceways that contain unmetered conductors must have provisions for sealing or locking by NHEC.

**MEMBER LOAD MONITORING**

The Member's load monitoring equipment must be installed only on the load side of the meter. No Member equipment is allowed inside a meter or current transformer enclosure.

**CLEARANCE REQUIREMENTS**

- The Member must provide and maintain the following clearances around all meter installations.
- The center of the meter must be between 5 and 5 1/2 feet above finished grade.
- A working space of 3 feet wide by 3 feet deep is required around the meter. This working space is to be kept clear of any obstructions including landscaping.

- Metering equipment must remain accessible, at all times.
- For propane device or equipment clearances, please see SP-4, located in the back of the book.
- Must meet the National Electrical Code clearance requirements.

## **ELECTRICAL ROOMS**

Meter sockets may be located inside an electrical equipment room. The electrical room must be used solely for power and communication equipment. The electrical room must be well lit, accessible during normal business hours, and not used for storage. The Member is responsible for providing a location near the door for installation of a key box, a key for the box, and for installing a sign on the exterior door saying "Electrical Room."

## **GROUNDING**

All meter sockets, enclosures, and conduit must be bonded and grounded in accordance with the latest edition of the NEC. A suitable means must be provided by the Member for attachment of other utilities to the Member's grounding electrode system.

## **SERVICES 400 AMPS OR LESS**

### **SERVICE CONDUCTORS FOR SELF-CONTAINED METERING**

Line-side conductors must always be connected to the top terminals of the meter socket. Service conductors must be arranged in the socket to avoid interfering with the meter installation or operation of the bypass. The member is responsible for ensuring that the connection of service entrance conductors in the meter socket are inspected and tightened before the service is energized. Meters will not be installed if conductors place undue strain on the terminal facilities. Terminals must be rated for the size of the conductor to be used. Strands must not be removed to make conductors fit under-sized terminals.

### **SEQUENCE OF EQUIPMENT**

All self-contained service equipment must be metered ahead of the disconnect switch. Under special conditions, permission may be granted to modify this sequence in multiple meter installations of more than six meters, provided that all equipment ahead of the meters is capable of being sealed by NHEC.

### **BASIC SINGLE-PHASE SERVICE**

The 120/240 volt, 200 ampere service is the most common service, and is typically installed on homes and some small businesses. However it is the Member's responsibility to determine electrical requirements and to notify NHEC of the service size needed.

### **SINGLE -PHASE 120/208 VOLT SERVICES**

A five terminal meter socket is required on all single-phase networked 120/208 volt service. The fifth terminal must be in the nine o'clock position, connected to the socket neutral bus conductor.

### **THREE-PHASE**

Three-phase service requires a seven terminal meter socket, the neutral (grounded) conductor must be connected to the third terminal from the left on the lower terminals.

## SERVICES GREATER THAN 400 AMP

Provisions for current transformers must be made when the current-carrying capacity of the **service entrance conductors** exceeds 400 amps single phase or three phase, as determined by NHEC.

### **The Member is responsible for the following:**

- **Member must supply load data survey sheet to the Meter Department for proper sizing of CT's. See page 7 for "Load Data Survey Sheet".**
- Provide and install a current transformer (CT) enclosure where designated by NHEC. The Member must install the CT enclosure on the supply side of the main disconnect, unless otherwise approved by NHEC's Meter Department.
- All CT enclosures require a minimum front clearance of 36 inches. Hinged CT enclosure doors must not block a safe exit or the meter while open. *Refer to Section 7 Specifications SP-4.*
- The top of the CT enclosure is a maximum of 8 feet above finished grade; the bottom is a minimum of 2 feet above the finished grade.
- All CT enclosures shall be located on the exterior of the building.
- All Member-supplied CT mounting equipment shall be listed and labeled, and shall be installed and used in accordance with any instructions included with that equipment.
- CT cabinet shall be mounted within 25' of the meter socket.
- CT cabinet and meter socket shall be mounted on the building wall, a back board or suitable pedestal.
- **NHEC may require a main breaker after the CT cabinet.**

## SERVICE EQUIPMENT

The Member is responsible for furnishing, installing, and maintaining all required service entrance equipment, including the service conductors to the point of delivery designated by NHEC. For services where current transformers (CTs) are required, the Member must also run conduit from the CT enclosure to the meter base. NHEC supplies the CTs and meter wiring.

## EQUIPMENT

Current transformer (CT) enclosures, switch gear, gutters that contain unmetered conductors, and metering equipment must have provisions for sealing. Contact NHEC's Meter Department to obtain access for inspection.

### **NHEC will furnish, install, and maintain the following equipment:**

- Revenue meters
- Current transformers
- CT meter wiring

### **The Member is responsible for furnishing, installing, and maintaining the following equipment beyond the point of delivery:**

- Approved meter sockets, see approved list for Meter Socket and CT enclosures on the NHEC website or call and one will be provided.
- All necessary wiring, connectors, and lugs (except CT meter wiring).
- Current transformer cabinet upon NHEC's approval.
- Switches
- Conduit

## CT METERING CIRCUIT CONDUIT.

NHEC requires 1 ¼ inch conduit between the meter socket and CT enclosure which shall be provided and installed by the Member. Conduit must be as short as possible and cannot exceed 25 feet in length, and shall be installed according to NHEC's requirements. A pull-string of 1/4 inch polypropylene rope is required in all meter conduits.

# Section 5: Utilization Equipment

---

## GENERAL

When Member owned equipment could or actually does interfere with the operation of any components of NHEC's electric system or the electric supply to others, NHEC reserves the right to refuse service or to disconnect their supply upon proper notice. Such instances include, but are not limited to, harmonic distortion, voltage fluctuations, and unacceptable transformer and capacitor installations.

Members must consult with NHEC in advance of making any commitments for large motors, welders, X-ray machines, or other equipment which may have a high instantaneous electric demand. NHEC will determine the effect such installations have on NHEC's system. Should NHEC determine that the installation is likely to cause interference with the electric system or the electric supply to others, NHEC may refuse to connect service, discontinue service, or require the Member to make modifications to their system. It is the Member's responsibility to determine and correct the problems such equipment may have on their own system.

## MOTOR INSTALLATIONS

The Member should ascertain from NHEC the character of service for the proposed location and application before purchasing motors and motor driven equipment. In general, motors of 3 hp. or less will be supplied from single phase services, and motors larger than 3 hp. will be supplied from three phase services.

The electrical limitations of the supply circuits may, in some cases, make it necessary to limit the size of the largest motor to be operated on any given part of NHEC's system. Written information as to such limitations is available upon inquiry to NHEC.

## NOTICE OF CHANGE IN LOAD

If you are adding significant equipment or load you must notify NHEC to ensure this additional load will not adversely affect NHEC's system or other Members. Significant equipment on a small single-phase service would include but is not limited to such equipment as a welder or five horsepower motor. Significant equipment on the larger services would be anything that increases load by 10%, and must have Engineering pre-approval.

- Under certain conditions where the quality of service to others is not impaired, NHEC may authorize the use of single phase motors larger than 3 hp. Approval to install larger motors must be in writing.
- All motors should be equipped with suitable protective devices, to protect from the following conditions.
  - Overloads
  - Voltage and frequency variations
  - Single phase operation of polyphase motors
  - Reversal of rotation in polyphase motors
- NHEC will not be responsible for damage caused to Member owned equipment where such damage is caused by the absence, failure, or misapplication of any Member owned protective device.
- NHEC will not be held responsible for damage caused by lightning or other acts of nature

## VOLTAGE SENSITIVE EQUIPMENT

Members owning or planning to purchase computer, reproduction, X-ray equipment or other voltage sensitive equipment, should consult the manufacturer of their equipment, and install suitable devices on their system to protect against power system transients and/or loss of voltage.

# Section 6: Generating Equipment Owned by Members

---

## **GENERAL**

The installation, connection, and operation of Member-owned generating equipment by a Member who takes service from NHEC may be restricted under the provisions of rates in NHEC's Tariff. The Member shall contact NHEC to obtain this information as part of the Member's planning to make an installation of generating equipment. Prior to operation of Member-owned generating equipment, NHEC shall have the right to inspect any Member-owned controlling and safety equipment associated with the generating equipment, together with the manner in which the generator is electrically connected to the Member's load and/or NHEC's electrical system to assure itself that the operation of this equipment will not create an undue risk of damage or injury to NHEC or its other Members.

## **STANDBY GENERATING EQUIPMENT**

Members may install generating equipment to serve as a standby source of electricity to supply all or a part of the Member's load in the event of an interruption in the supply of electricity from NHEC. The Member's interconnection shall be arranged so that no electrical connection can occur between NHEC's service and the Member's standby source of supply. The standby source shall be controlled through the use of a double throw switch, (Refer to Construction Standard DPS1 located in the back of the book) installed in a manner acceptable to NHEC, and designed to prevent the possibility of any electrical connection between NHEC's normal electrical supply and the Member's standby source. At NHEC's discretion, the Member's standby source may be allowed to connect with NHEC's supply provided certain conditions set forth by NHEC are addressed by the Member.







# Back-up Generator Registration Form

If you own an emergency / stand-by electric generator to supply power during outages, it is critical for your safety and the safety of New Hampshire Electric Co-op line crews that your equipment be properly installed and that the Co-op is aware that you have a generator. Please fill out the following form so that we can update our records to reflect your installation.

## NHEC Account Information

---

Today's Date \_\_\_\_\_ Phone Number \_\_\_\_\_

Name \_\_\_\_\_

Address \_\_\_\_\_  
\_\_\_\_\_

Account Number \_\_\_\_\_

## Generator Information

---

Generator Size (In Watts) \_\_\_\_\_ Brand Name \_\_\_\_\_

Installation Date (Month & Year) \_\_\_\_\_ Fuel Type \_\_\_\_\_

Transfer Switch? Yes \_\_\_ No \_\_\_ (If Yes) Type: Automatic \_\_\_ Manual \_\_\_ Model \_\_\_\_\_

Installation by Licensed Electrician? Yes \_\_\_ No \_\_\_ Inspection by Licensed Electrician? Yes \_\_\_ No \_\_\_

## NHEC Use

---

Reviewed By \_\_\_\_\_

Record Updated \_\_\_\_\_

Follow-up \_\_\_\_\_

## Return To:

Generator Registration  
New Hampshire Electric Cooperative  
579 Tenney Mountain Hwy.  
Plymouth, NH 03264

## Questions:

Telephone: 1-800-698-2007  
Email: [nhechq@nhec.com](mailto:nhechq@nhec.com)



# Section 7: Specifications

---



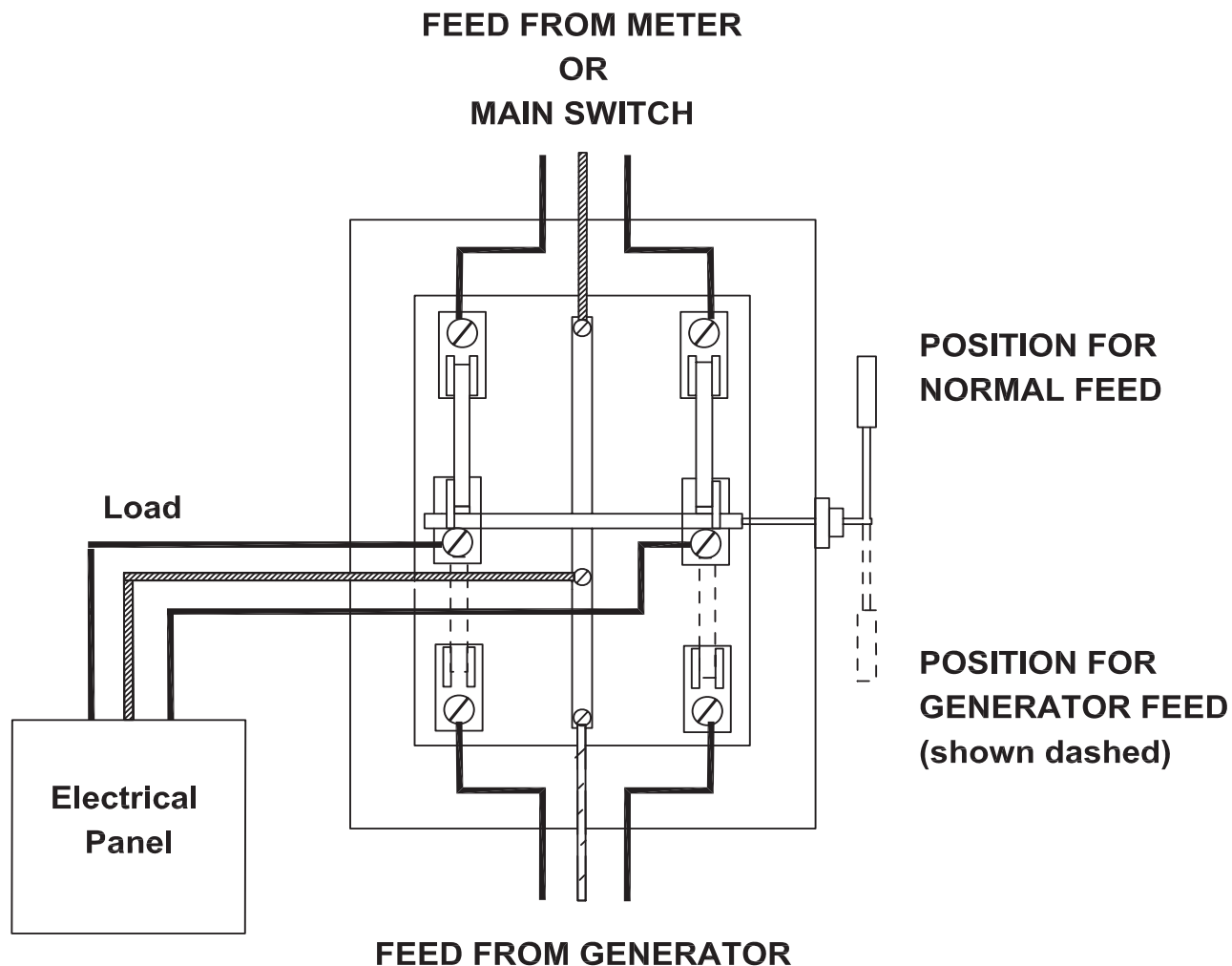

1. TYPICAL DOUBLE POLE-DOUBLE THROW SWITCH INSTALLATION FOR USE WITH A BACK-UP GENERATOR.
2. NHEC RECOMMENDS THAT ONLY THOSE CIRCUITS NEEDED IN AN EMERGENCY (i.e.: OIL BURNER, ONE LIGHTING CIRCUIT, etc) BE ISOLATED IN A SEPARATE ELECTRIC PANEL, AS MOST GENERATORS ARE NOT LARGE ENOUGH FOR THE LOAD DEMANDED BY ALL YOUR HOUSEHOLD APPLIANCES. AS ILLUSTRATED, THIS ELECTRIC PANEL CAN BE FED FROM EITHER YOUR MAIN SWITCH OR THE GENERATOR.
3. IF THE GENERATOR IS LARGE ENOUGH TO CARRY YOUR ENTIRE LOAD, THE MAIN SWITCH MAY BE CONNECTED TO THE LOAD SIDE OF THE DOUBLE POLE-DOUBLE THROW SWITCH. THE FEED TO THIS SWITCH WOULD THEN BE FROM YOUR GENERATOR OR DIRECTLY FROM OUR METER.
4. NHEC URGES YOU TO CONTACT A QUALIFIED ELECTRICIAN OR THE SUPPLIER OF THE GENERATOR TO DETERMINE THE OPERATING LIMITS OF THE UNIT YOU PURCHASE.
5. PLEASE NOTIFY NHEC AT 1-800-698-2007, IF AND WHEN YOU INSTALL A BACK-UP GENERATOR, SO WE CAN UPDATE OUR RECORDS TO REFLECT YOUR INSTALLATION.



CONSTRUCTION STANDARDS  
 DOUBLE POLE - DOUBLE THROW SWITCH  
 FOR  
 BACK-UP GENERATOR

DPS 1

ISSUE DATE: 06/05

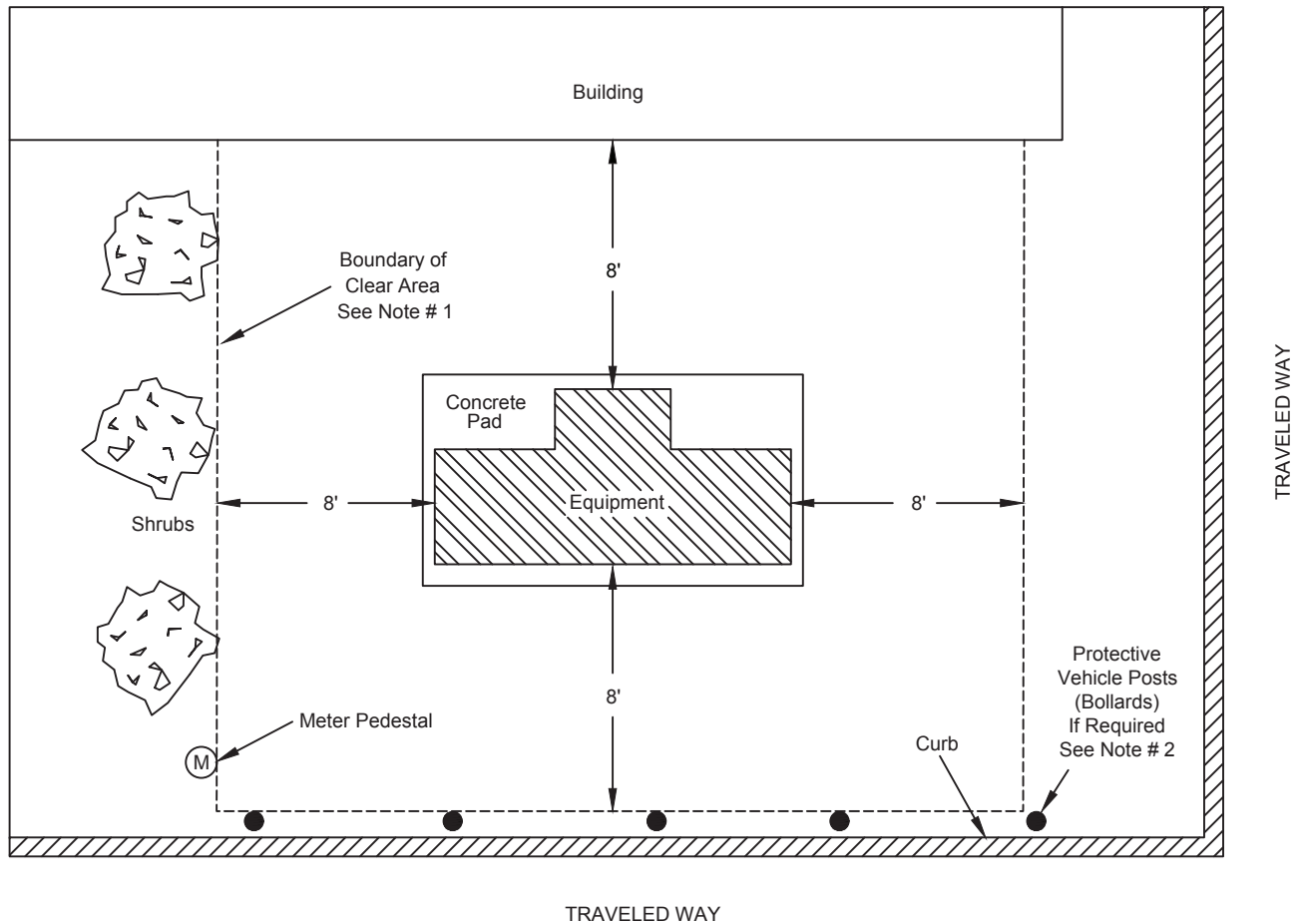

**MINIMUM CLEARANCES TO PADMOUNT TRANSFORMER EQUIPMENT**

Non-Combustable Walls	8'	Bollards, Meters, Sprinkler Valves, Standpipe or Hydrant	8'
Combustable Walls, Doors, Windows, Vents, Other Openings, Fire escapes	10'	Above Grade Fuel Tanks/Meters	10'
Driveways, Parking Lots, and/or Traveled Ways	10'	Natural Gas or Propane Connections/Meters	15'
Sidewalks	8'	Gasoline Dispensing Units	20'
Property Lines (from sides of equipment)	8'	Facilities used to dispense or store hazardous liquids or gases; (example, service station gas pumps and tanks, propane bulk dispensing tanks and emergency generator fueling points.)	
Property Lines (from doors of equipment)	10'		
Shrubs	8'		20'
Pools	15'	Electrical Padmount Equipment	8'

**NOTES**

- 1.) To inspect, provide access, operate and ventilate the equipment, the above specified clear area distances to buildings or shrubs shall be maintained. All distances shall be measured from the nearest surface of the equipment. Property lines shall be considered an obstruction, since fences, shrubs, etc. may be installed at a future date by adjacent property owners.
- 2.) If no curb exists, or transformer is located closer than 10' to the traveled way, protective vehicle posts (●) shall be installed.
- 3.) Top of transformer pad shall be installed 6" above finished grade.
- 4.) Transformer shall not be located on steep grades where access is made difficult.
- 5.) Transformer IS NOT to be located with its doors facing the building.



**SPECIFICATIONS**

**CLEARANCES FOR PADMOUNT EQUIPMENT**

**SP-2**

ISSUE DATE: 11/2016

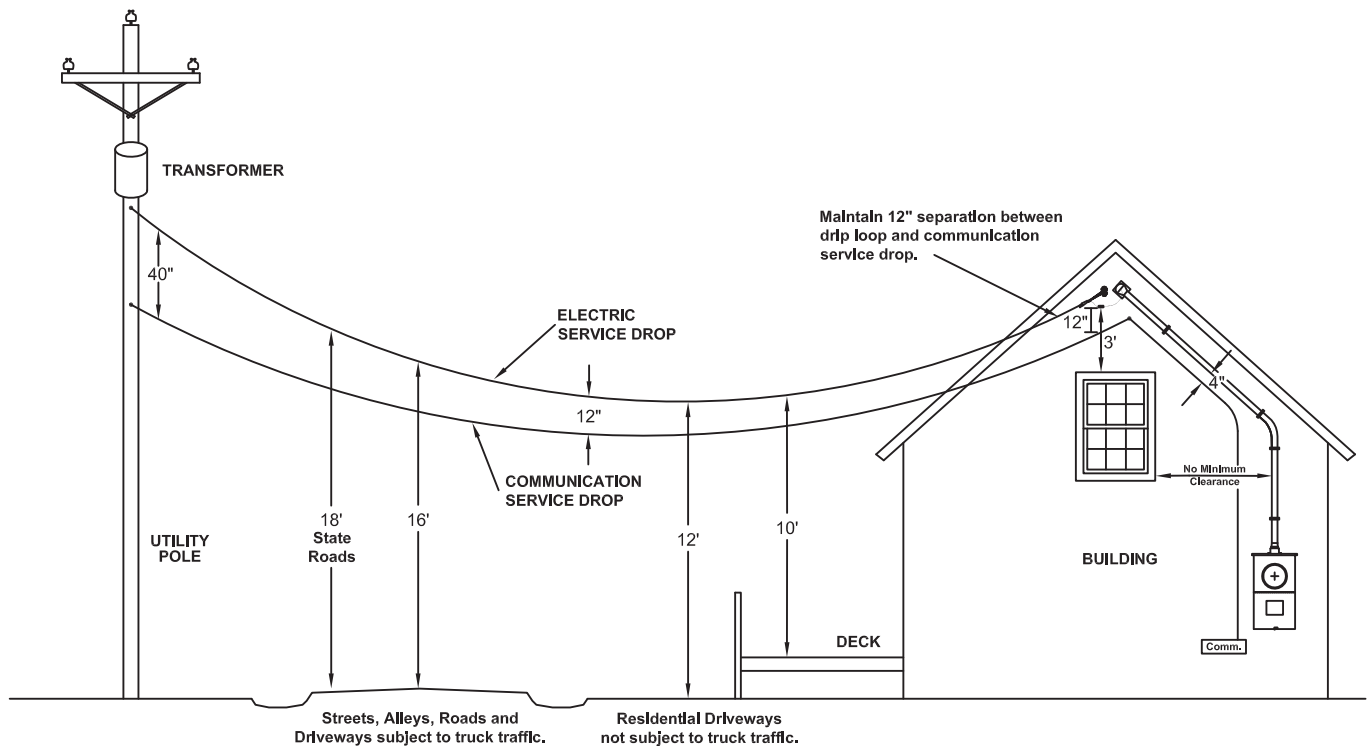

**NOTES:**

1. Separation from Electric Service Drop (TPLX) and Communication Service Drop at Pole is 40" NESC 235-5 Table 1(a).
2. Separation from Electric Service Drop (TPLX) and Communication Service Drop at any point in the span including the point of attachment is 12" NESC 235(C)1 and NEC 800.44(A)4.
3. Separation from Service Entrance Conductors and Communication Service Drop running down the side of the building is 4" NEC 800.50(B).
4. Electric Service Drop (TPLX) conductors and connections shall have a clearance of 3' in any direction from windows that are designed to be open, doors, porches, balconies, ladders, stairs, fire escapes and similar locations, except when run above the top level of the window. NESC 234(C)3d2 and NEC 230.9(A)  
 Note 4a) There are no minimal clearances for SEU, SER, PVC, EMT, or Rigid Metal Conduit from open portions of windows.
5. Service Weather-Heads shall be located above the Electric Service Drop point of attachment and shall not be farther than 24" NEC 230.54(C).
6. Electric Service Drop Vertical Clearances Above Ground please reference NESC 232-1 Table including Footnotes.
7. Vertical Clearance, from highest point of readily accessible roofs, balconies, porches, or decks over which they pass is 10' NESC 234(C)3d and NEC 230.24(B)1.  
 Note 7a) When the roof or balcony is not readily accessible the clearance including the drip loop shall not be less than 3' when Electric Service Drop is owned by the Utility.  
 Note 7b) If Electric Service Drop is privately owned the Vertical Clearance above roofs is 8' NEC 230.24(A).  
 Note 7c) A roof, balcony, porch, or attached deck is considered readily accessible to pedestrians if it can be casually accessed through a doorway, window, ramp, stairway, or permanently mounted ladder by a person, on foot, who neither exerts extraordinary physical effort nor employs tools or devices to gain entry. A permanently mounted ladder is not considered a means of access if its bottom rung is 8 ft or more from the ground or other permanently installed accessible surface.
8. Trucks are defined as any vehicle exceeding 8 ft in height.



SPECIFICATIONS  
SERVICE CLEARANCES

**SP-3**

ISSUE DATE: 09/13

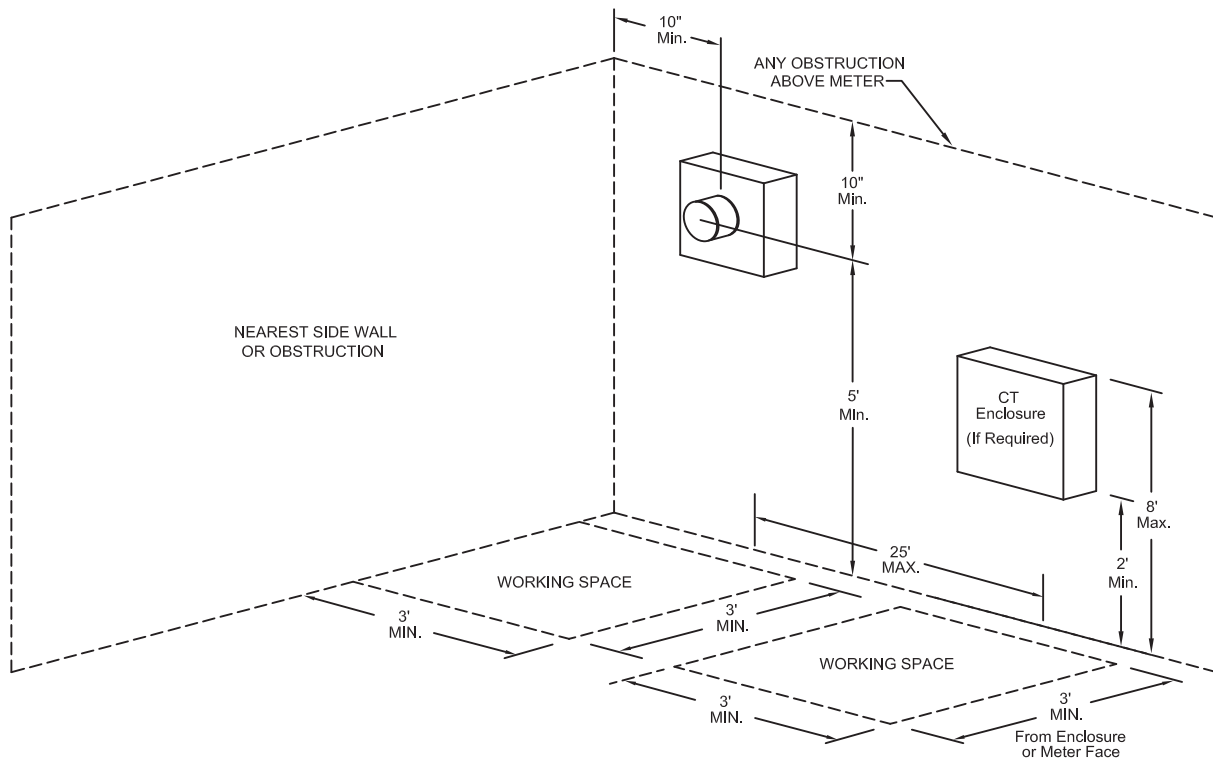

**PREFERRED INSTALLATION  
METER SOCKET & CT ENCLOSURE MINIMUM CLEARANCES**

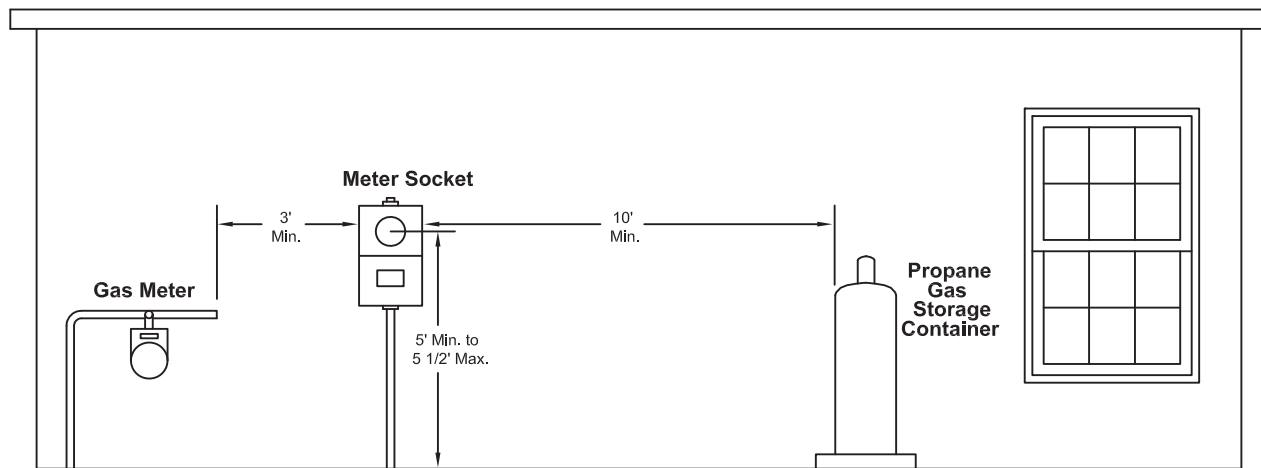

**METER SOCKET TO GAS METER & STORAGE CONTAINER CLEARANCES**



**SPECIFICATIONS**

**MINIMUM METER & METER SOCKET CLEARANCES**

**SP-4**

ISSUE DATE: 05/2012



### MATERIALS FURNISHED AND INSTALLED BY MEMBER

- ① **WEATHER HEAD**
- ② **SERVICE ENTRANCE CABLE**  
TO BE INSTALLED WITH ENDS EXTENDING 3'-0" OUTSIDE OF WEATHER HEAD FOR DRIP LOOP.
- ③ **CABLE CLIPS**  
INSTALLED EVERY 36".
- ④ **WATERTIGHT CONNECTOR**
- ⑤ **METER SOCKET WITH HUB**  
SECURELY ATTACHED TO SUPPORTING STRUCTURE.
- ⑥ **FUSED OUTDOOR DISCONNECT SWITCH OR BREAKER**  
RATED AT LEAST 60 AMPS.  
MUST BE WEATHERPROOF.
- ⑦ **GROUND FAULT CIRCUIT INTERRUPTER**
- ⑧ **WATERPROOF RECEPTACLE**
- ⑨ **GROUND WIRE**  
NO. 6 COPPER (MIN. SIZE)
- ⑩ **GROUND ROD CONNECTORS**
- ⑪ **GROUND RODS**  
(2) MIN. 8'-0" x 5/8" DIAMETER COPPER CLAD.
- ⑫ **SUPPORTING STRUCTURE**  
A.) NO LESS THAN 6" x 6".  
B.) TALL ENOUGH TO PROVIDE MINIMUM GROUND CLEARANCE.  
C.) SET 3' MINIMUM IN THE GROUND.

### MATERIALS FURNISHED AND INSTALLED BY NHEC

- METER  
SERVICE DROP CONDUCTORS,  
WIRE HOLDER & CONNECTORS

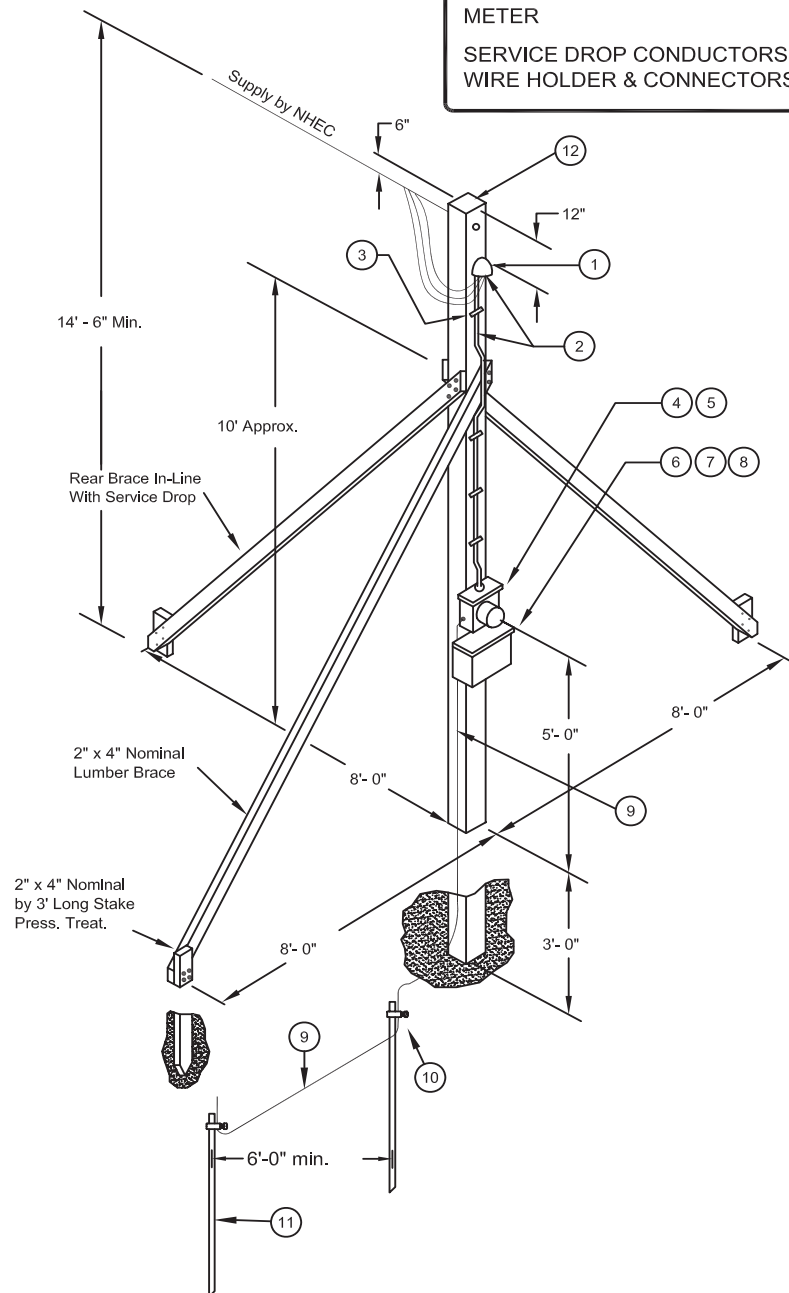
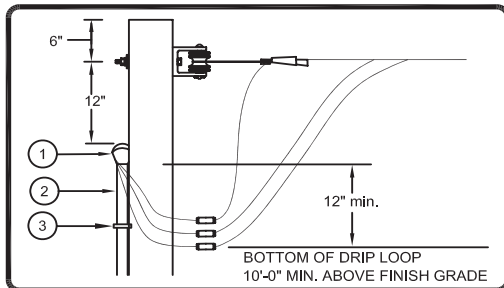

### NOTES:

- 1.) PLEASE CALL NHEC AND MAKE ARRANGEMENTS TO HAVE THE METER LOCATION APPROVED BEFORE MAKING ANY CHANGES IN YOUR PRESENT ENTRANCE OR INSTALLING A NEW ENTRANCE.
- 2.) ALL WIRING AND MATERIALS MUST CONFORM TO THE REQUIREMENTS OF THE NATIONAL ELECTRICAL CODE AND TO APPLICABLE LOCAL CODES. WHERE CONFLICT EXISTS, THE MORE STRINGENT CODE WILL APPLY.
- 3.) MAXIMUM TIME LIMIT OF THIS SERVICE IS 12 MONTHS.
- 4.) SERVICE STRUCTURE SHALL NOT BE FURTHER THAN 75 FEET AWAY FROM LAST NHEC ATTACHMENT AS ARRANGED WITH FIELD REPRESENTATIVE.
- 5.) ALTERNATIVE SUPPORTING ARRANGEMENTS MAY BE USED IF ALL CLEARANCE AND GROUNDING REQUIREMENTS OF THE NEC ARE SATISFIED AND THE AUTHORITY HAVING JURISDICTION IS IN AGREEMENT.

**MATERIALS FURNISHED AND INSTALLED BY MEMBER**

- ① **WEATHER HEAD**
- ② **SERVICE ENTRANCE CABLE**  
TO BE INSTALLED WITH ENDS EXTENDING 3'-0" OUTSIDE OF WEATHER HEAD FOR DRIP LOOP.
- ③ **CABLE CLIPS**  
INSTALLED EVERY 36".
- ④ **WATERTIGHT CONNECTOR**
- ⑤ **GROUND WIRE**  
NO. 6 COPPER (MINIMUM SIZE)
- ⑥ **GROUND ROD CONNECTORS**
- ⑦ **GROUND RODS**  
(2) MIN. 8'-0" x 5/8" DIAMETER COPPER CLAD.
- ⑧ **METER SOCKET WITH HUB**  
SOCKET MUST HAVE INTEGRATED MAIN CIRCUIT BREAKER(S). TO BE SECURELY ATTACHED TO BUILDING BY CONSUMER.

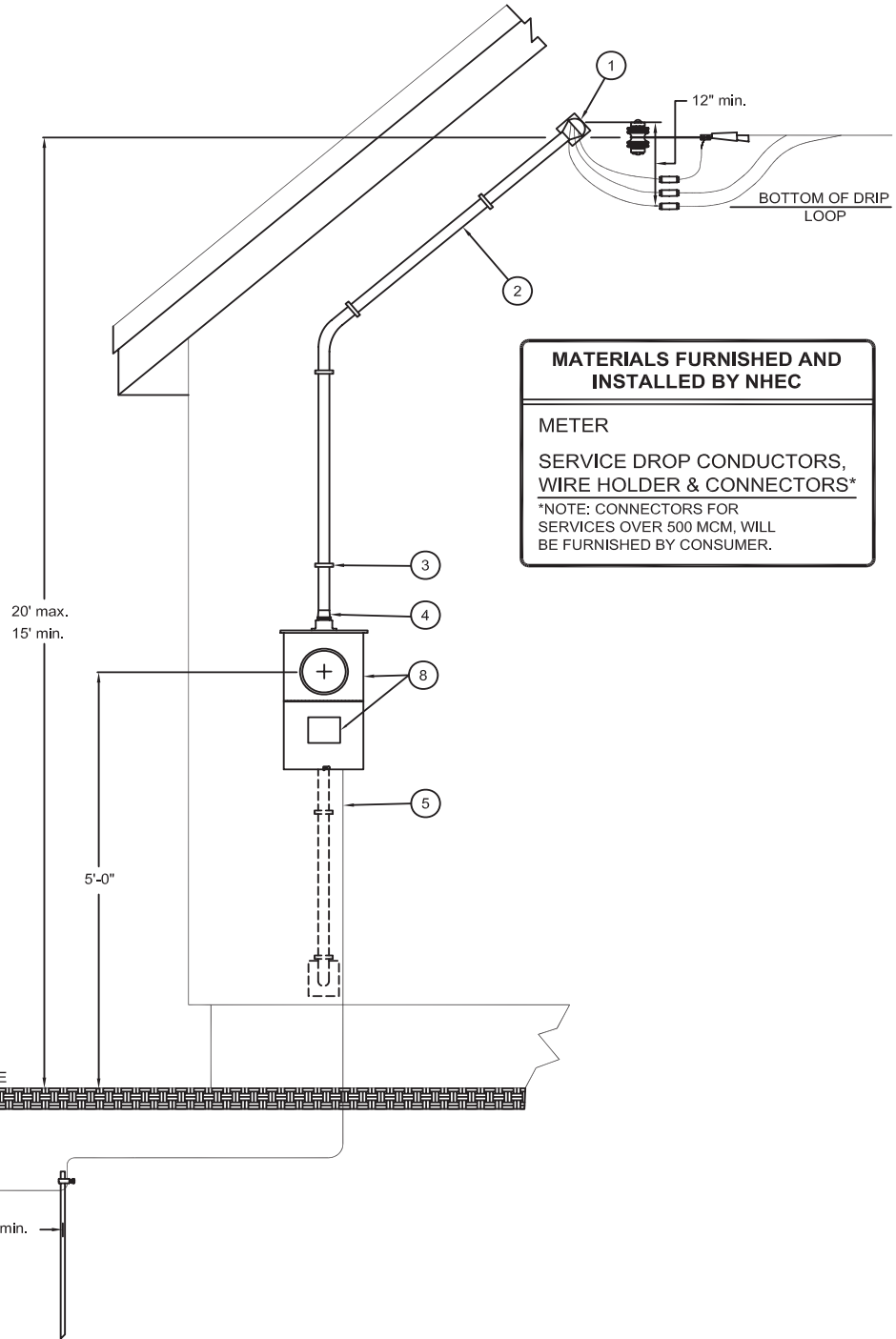

**MATERIALS FURNISHED AND INSTALLED BY NHEC**

METER

SERVICE DROP CONDUCTORS, WIRE HOLDER & CONNECTORS\*

\*NOTE: CONNECTORS FOR SERVICES OVER 500 MCM, WILL BE FURNISHED BY CONSUMER.

**NOTES:**

- 1.) PLEASE CALL NHEC AND MAKE ARRANGEMENTS TO HAVE THE METER LOCATION APPROVED BEFORE MAKING ANY CHANGES IN YOUR PRESENT ENTRANCE OR INSTALLING A NEW ENTRANCE.
- 2.) FOUR WIRE CABLE MUST BE INSTALLED FROM METER SOCKET TO DISTRIBUTION PANEL.



CONSTRUCTION STANDARDS

ENTRANCE INSTALLATION  
SINGLE RESIDENCE

- | MATERIALS FURNISHED BY MEMBER AND INSTALLED BY NHEC   |   |
|---|---|
| ①   | <b>WEATHER HEAD</b><br>LOCATED AT TOP OF POLE.  |
| ②   | <b>SERVICE ENTRANCE CONDUCTORS</b><br>TO BE INSTALLED IN CONDUIT WITH ENDS EXTENDING 3'-0" OUTSIDE OF WEATHER HEAD FOR DRIP LOOP.         |
| ③   | <b>CONDUIT</b><br>CONDUIT MAY BE EITHER SCHEDULE 80 PVC OR GALVANIZED STEEL.  |
| ④   | <b>PIPE STRAPS</b><br>INSTALLED PER N.E.C.  |
| MATERIALS FURNISHED BY MEMBER AND INSTALLED BY MEMBER |   |
| ⑤   | <b>MOUNTING BOARD</b><br>MINIMUM 3/4" PRESSURE TREATED MATERIAL OR METAL BRACKETS FOR MOUNTING METER SOCKET DIRECTLY TO THE POLE.         |
| ⑥   | <b>METER SOCKET WITH HUB</b><br>SOCKET MUST HAVE INTEGRATED MAIN CIRCUIT BREAKER(S). TO BE SECURELY ATTACHED TO MOUNTING BOARD BY MEMBER. |
| ⑦   | <b>GROUND WIRE</b><br>NO. 6 COPPER (MIN. SIZE) BONDED TO GALVANIZED STEEL CONDUIT BY MEMBER AS REQ'D.                                     |
| ⑧   | <b>GROUND ROD CONNECTORS</b>  |
| ⑨   | <b>GROUND RODS</b><br>(2) MIN. 8'-0" x 5/8" DIAMETER COPPER CLAD.   |

- | MATERIALS FURNISHED AND INSTALLED BY NHEC         |  |
|---|--|
| POLE, METER                                       |  |
| SERVICE DROP CONDUCTORS, WIRE HOLDER & CONNECTORS |  |

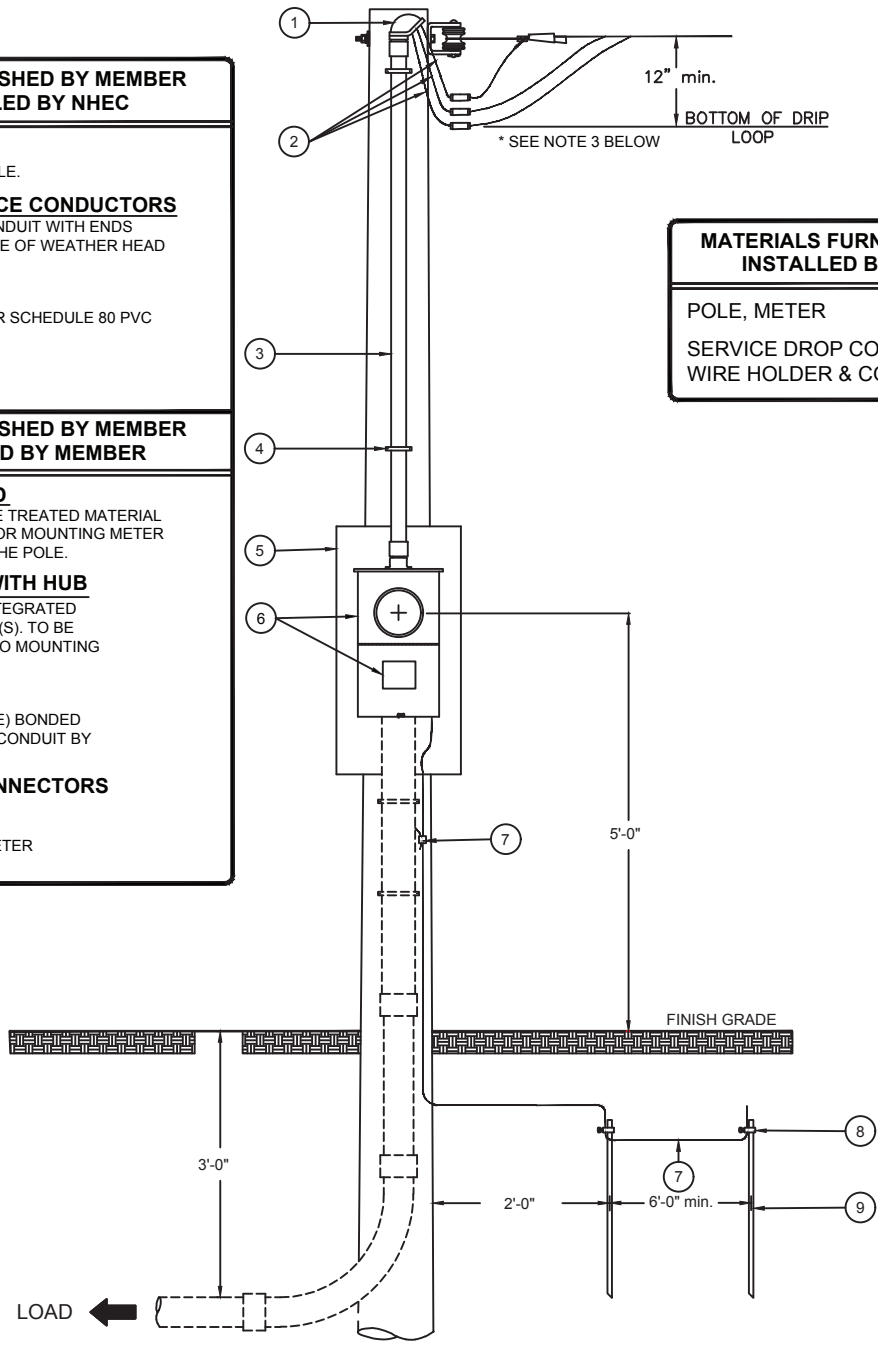

**NOTES:**

- PLEASE CALL NHEC AND MAKE ARRANGEMENTS TO HAVE THE METER LOCATION APPROVED BEFORE MAKING ANY CHANGES IN YOUR PRESENT ENTRANCE OR INSTALLING A NEW ENTRANCE.
- MOBILE HOME METER LOCATION SHALL BE READILY ACCESSIBLE, IN SIGHT, AND NOT MORE THAN 30 FEET FROM EXTERIOR WALL OF MOBILE HOME IT SERVES. IF DISTANCE EXCEEDS 30 FEET, A SECOND DISCONNECT SWITCH IS REQUIRED.
- CONDUIT AND WEATHER HEAD MUST EXTEND TO THE TOP OF THE POLE AS SHOWN TO PROVIDE CLEARANCE FOR TEL & CATV ATTACHMENTS. RISER MATERIAL ABOVE METER TO BE FURNISHED BY MEMBER AND INSTALLED BY NHEC
- FOUR WIRE CABLE MUST BE INSTALLED FROM METER SOCKET TO DISTRIBUTION PANEL.



CONSTRUCTION STANDARDS  
OVERHEAD SERVICE INSTALLATION  
REMOTE METER ON POLE  
SINGLE RESIDENCE

SE 2

ISSUE DATE: 11/2016

MATERIALS FURNISHED BY MEMBER AND INSTALLED BY NHEC	
①	<b>WEATHER HEAD</b> LOCATED AT TOP OF POLE.
②	<b>SERVICE ENTRANCE CONDUCTORS</b> TO BE INSTALLED IN CONDUIT WITH ENDS EXTENDING 3'-0" OUTSIDE OF WEATHER HEAD FOR DRIP LOOP.
③	<b>CONDUIT</b> CONDUIT MAY BE EITHER SCHEDULE 80 PVC OR GALVANIZED STEEL.
④	<b>PIPE STRAPS</b> INSTALLED PER N.E.C.
MATERIALS FURNISHED BY MEMBER AND INSTALLED BY MEMBER	
⑤	<b>MOUNTING BOARD</b> MINIMUM 3/4" PRESSURE TREATED MATERIAL OR METAL BRACKETS FOR MOUNTING METER SOCKET DIRECTLY TO THE POLE.
⑥	<b>METER SOCKET WITH HUB</b> SOCKET MUST HAVE INTEGRATED MAIN CIRCUIT BREAKER(S). TO BE SECURELY ATTACHED TO MOUNTING BOARD BY MEMBER.
⑦	<b>GROUND WIRE</b> NO. 6 COPPER (MIN. SIZE) BONDED TO GALVANIZED STEEL CONDUIT BY MEMBER AS REQ'D.
⑧	<b>GROUND ROD CONNECTORS</b>
⑨	<b>GROUND RODS</b> (2) MIN. 8'-0" x 5/8" DIAMETER COPPER CLAD.

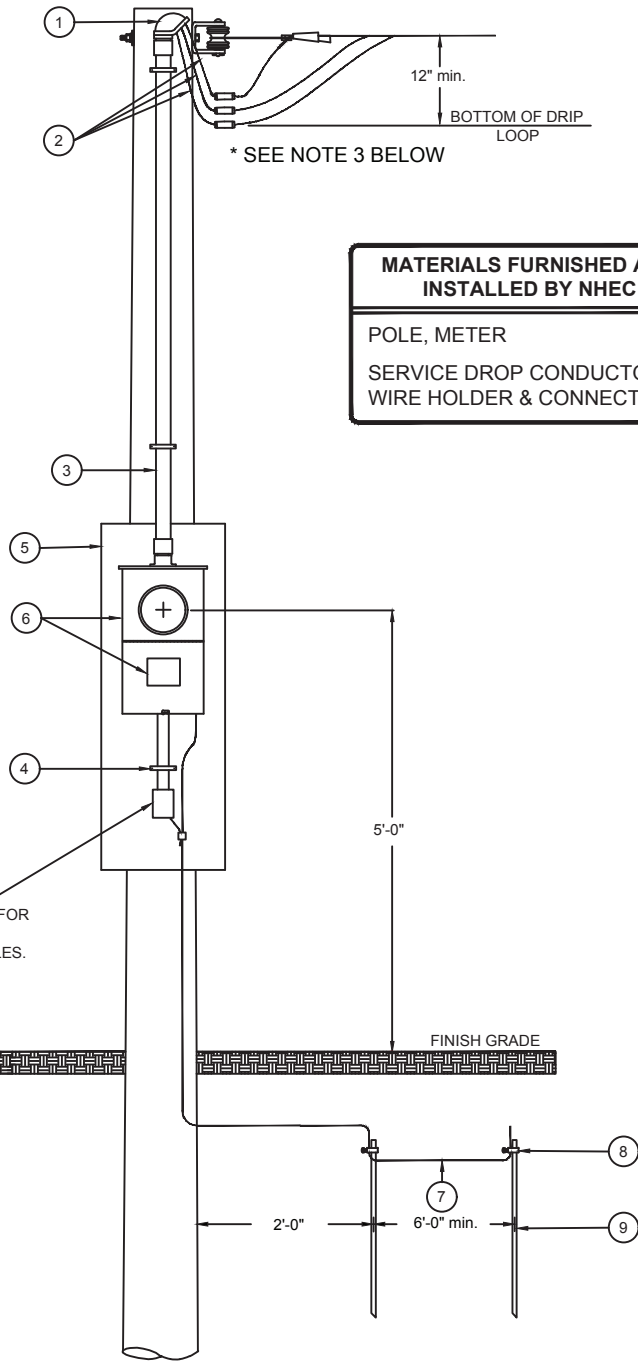

MATERIALS FURNISHED AND INSTALLED BY NHEC	
POLE, METER	
SERVICE DROP CONDUCTORS, WIRE HOLDER & CONNECTORS	

TYPICAL INSTALLATION. CHECK LOCAL & NEC CODES FOR REQUIREMENTS ON GFI AND WEATHERPROOF RECEPTACLES.

**NOTES:**

- PLEASE CALL NHEC AND MAKE ARRANGEMENTS TO HAVE THE METER LOCATION APPROVED BEFORE MAKING ANY CHANGES IN YOUR PRESENT ENTRANCE OR INSTALLING A NEW ENTRANCE.
- MOBILE HOME METER LOCATION SHALL BE READILY ACCESSIBLE, IN SIGHT, AND NOT MORE THAN 30 FEET FROM EXTERIOR WALL OF MOBILE HOME IT SERVES. IF DISTANCE EXCEEDS 30 FEET, A SECOND DISCONNECT SWITCH IS REQUIRED.
- CONDUIT AND WEATHER HEAD MUST EXTEND TO THE TOP OF THE POLE AS SHOWN TO PROVIDE CLEARANCE FOR TEL & CATV ATTACHMENTS. RISER MATERIAL ABOVE METER TO BE FURNISHED BY MEMBER AND INSTALLED BY NHEC.



CONSTRUCTION STANDARDS  
OVERHEAD SERVICE INSTALLATION  
REMOTE METER ON POLE  
TRAVEL TRAILERS, MOTOR HOMES, ETC.

SE 3

ISSUE DATE: 11/2016

- MATERIALS FURNISHED AND INSTALLED BY MEMBER**
- ① WEATHER HEAD
  - ② INSULATED CONDUIT CLEVIS
  - ③ CONDUIT HANGERS
  - ④ CONDUIT  
GALVANIZED STEEL
  - ⑤ SERVICE ENTRANCE CONDUCTORS  
TO BE INSTALLED WITH ENDS EXTENDING 3'-0" OUTSIDE OF WEATHER HEAD FOR DRIP LOOP.
  - ⑥ GROUND WIRE  
NO. 6 COPPER (MINIMUM SIZE)
  - ⑦ GROUND ROD CONNECTORS
  - ⑧ GROUND RODS  
(2) MIN. 8'-0" x 5/8" DIAMETER COPPER CLAD.
  - ⑨ METER SOCKET WITH HUB  
SOCKET MUST HAVE INTEGRATED MAIN CIRCUIT BREAKER(S). TO BE SECURELY ATTACHED TO BUILDING BY CONSUMER.
  - ⑩ COUPLING  
ALL CONDUIT COUPLINGS SHALL BE LOCATED BELOW ROOF EVE.

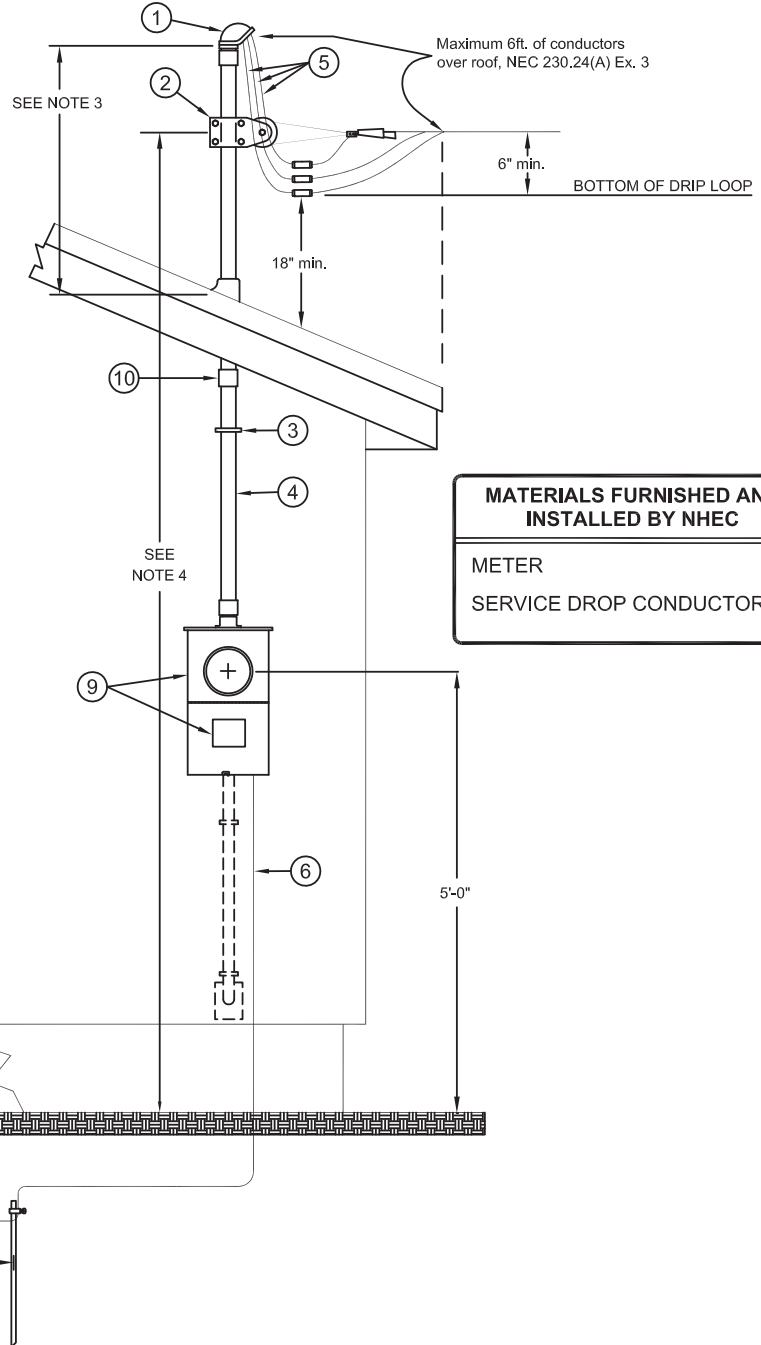

- MATERIALS FURNISHED AND INSTALLED BY NHEC**
- METER
  - SERVICE DROP CONDUCTORS

**NOTES:**

- 1.) Please call NHEC and make arrangements to have the meter location approved before making any changes in your present entrance or installing a new entrance.
- 2.) The point of attachment on the building to be determined by the required minimum ground clearances of service drop conductors. Attachment heights in excess of 20 feet are subject to NHEC approval.
- 3.) The member assumes the responsibility that the service mast is of adequate strength. If service mast is greater than 3 feet additional supports, braces or guys will be required.
- 4.) Four wire cable must be installed from meter socket to distribution panel.
- 5.) Only Electric Service Drop conductors shall be permitted to be attached to a Service Mast. NEC 230.28.
- 6.) No more than 6' of conductors pass over no more than 4' of roof. NEC 230.24(A) Ex 3.  
Note 6.1) For this rule, conductor length is totaled by Electric Service Drop (TPLX) and Service Entrance Conductors outside of the Service Mast.



### MATERIALS FURNISHED AND INSTALLED BY MEMBER

- ① **SUPPORT POST**  
6" x 6" MIN. SQUARE OR 8" DIA. MIN. ROUND.
- ② **METER SOCKET**  
NEEDS TO BE SECURELY ATTACHED TO POST.
- ③ **SERVICE ENTRANCE CABLE**  
CONNECTION TO TRANSFORMER MADE BY COOPERATIVE.
- ④ **PIPE STRAPS**
- ⑤ **2" CONDUIT**  
LIQUIDTIGHT FLEXIBLE NON-METALLIC CONDUIT; TYPE LFNC MAY BE USED FOR THIS INSTALLATION IN LIEU OF SCHEDULE 80 PVC OR GALVANIZED STEEL & INSULATED BUSHING. ATTACH TO TRANSFORMER VIA KNOCKOUT PANEL.
- ⑥ **GROUND WIRE**  
NO. 6 COPPER (MIN. SIZE) BONDED TO GALVANIZED STEEL CONDUIT BY CONSUMER AS REQ'D.
- ⑦ **GROUND ROD CONNECTORS**
- ⑧ **GROUND RODS**  
(2) MIN. 8'-0" x 5/8" DIAMETER COPPER CLAD.

### MATERIALS FURNISHED AND INSTALLED BY NHEC

METER

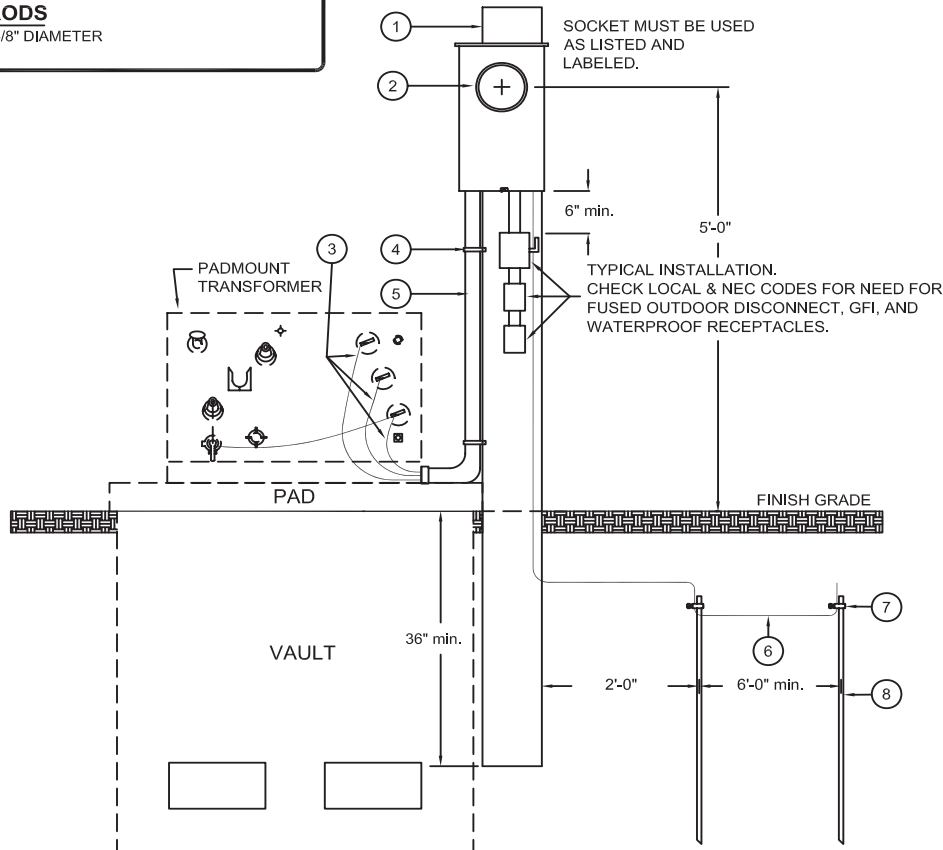

**NOTES:**

- 1.) PLEASE CALL NHEC AND MAKE ARRANGEMENTS TO HAVE THE METER LOCATION APPROVED BEFORE MAKING ANY CHANGES IN YOUR PRESENT ENTRANCE OR INSTALLING A NEW ENTRANCE.
- 2.) MAXIMUM TIME LIMIT OF THIS SERVICE IS 12 MONTHS.
- 3.) REFER TO SECTION 2 FOR FURTHER CLARIFICATION AND DETAILED DESCRIPTIONS FOR UNDERGROUND INSTALLATIONS.



**CONSTRUCTION STANDARDS**  
TEMPORARY  
ENTRANCE INSTALLATION  
SINGLE RESIDENCE

# UTS 1

ISSUE DATE: 06/05

### MATERIALS FURNISHED AND INSTALLED BY CONSUMER

- ① **SUPPORT POST**  
2" x 8" x 8' OR 10'  
**OR SECTION OF WALL**
- ② **METER SOCKET**  
NEEDS TO BE SECURELY ATTACHED TO POST.
- ③ **SERVICE ENTRANCE CABLE**
- ④ **PIPE STRAPS**
- ⑤ **3" OR 4" CONDUIT**
- ⑥ **GROUND WIRE**  
NO. 6 COPPER (MIN. SIZE) BONDED TO GALVANIZED STEEL CONDUIT BY CONSUMER AS REQ'D.
- ⑦ **GROUND ROD CONNECTORS**
- ⑧ **GROUND RODS**  
(2) MIN. 8'-0" x 5/8" DIAMETER COPPER CLAD.
- ⑨ **3" OR 4" SLIP-JOINT**  
FROST HEAVE PROTECTION
- ⑩ **3" OR 4" CONDUIT (IF NEEDED)**  
SCHEDULE 80 PVC.
- ⑪ **3" OR 4" ADAPTER (IF NEEDED)**
- ⑫ **3" OR 4" 90°, 36" RADIUS SWEEP**  
(SEE NOTE 6)
- ⑬ **CAUTION RIBBON**  
RED, 6" WIDE CAUTION RIBBON, MUST SAY "ELECTRICAL LINE BURIED BELOW".
- ⑭ **1/4" POLYPROPYLENE STRING**  
INSTALLED IN ALL CONDUITS WITH STRING EXPOSED AND TIED OFF AT ENDS THRU CAPS AT END OF CONDUIT.

**UNDERGROUND SERVICE LATERAL CONDUCTORS**  
TO BE INSTALLED BY COOPERATIVE.

### MATERIALS FURNISHED AND INSTALLED BY NHEC

**METER**

**UNDERGROUND SERVICE LATERAL CONDUCTORS**  
FURNISHED AND INSTALLED BY COOPERATIVE FOR BASIC SERVICE.  
FURNISHED BY CONSUMER FOR LARGE BASIC SERVICE.

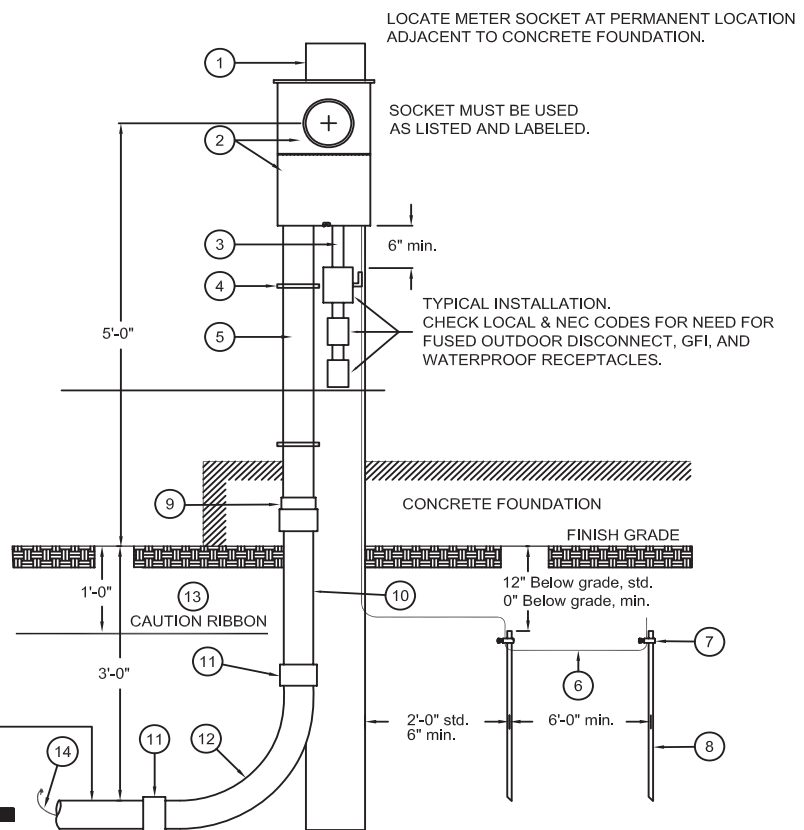

### NOTES:

- 1.) PLEASE CALL THE DISTRICT OFFICE OF THE COOPERATIVE AND MAKE ARRANGEMENTS TO HAVE THE METER LOCATION APPROVED BEFORE MAKING ANY CHANGES IN YOUR PRESENT ENTRANCE OR INSTALLING A NEW ENTRANCE.
- 2.) ALL CONDUIT AND ACCESSORIES MUST MEET ELECTRICAL GRADE SPECIFICATIONS.
- 3.) ALL SERVICE ENTRANCE WIRING MUST BE COMPLETE AND ALL NECESSARY EXCAVATION AND CONDUIT READY PRIOR TO THE TIME OF INSTALLATION OF THE UNDERGROUND SERVICE LATERAL CONDUCTORS BY NHEC.
- 4.) ALL WIRING AND MATERIALS MUST CONFORM TO THE REQUIREMENTS OF THE NATIONAL ELECTRICAL CODE AND TO APPLICABLE LOCAL CODES. WHERE CONFLICT EXISTS, THE MORE STRINGENT CODE WILL APPLY.
- 5.) THE MEMBER IS RESPONSIBLE FOR ALL TRENCHING. REFER TO COOPERATIVE DISTRIBUTION STANDARDS FOR TRENCHING SPECIFICATIONS.
- 6.) AN ELECTRICAL GRADE SCHEDULE 40 PVC 90° SWEEP WITH A MINIMUM RADIUS OF 36 INCHES MAY BE SUBSTITUTED IN STRAIGHT RUNS BETWEEN RISER POLE AND METER FOR 500 U.S.E. LESS THAN 150 FEET, FOR 4/0 U.S.E. LESS THAN 200 FEET, AND FOR 1/0 U.S.E. LESS THAN 200 FEET IN LENGTH. IF RUNS EXCEED THESE LIMITS , THEN ALL 90° SWEEPS MUST BE GALVANIZED STEEL AND BONDED.
- 7.) MAXIMUM TIME LIMIT OF THIS SERVICE IS 12 MONTHS.
- 8.) GALVANIZED STEEL CONDUIT MUST BE BONDED TO GROUND WIRE, AS REQUIRED.
- 9.) FOUR WIRE CABLE MUST BE INSTALLED FROM METER SOCKET TO DISTRIBUTION PANEL.
- 10.) REFER TO SECTION 2 FOR FURTHER CLARIFICATION AND DETAILED DESCRIPTIONS FOR UNDERGROUND INSTALLATIONS.



**CONSTRUCTION STANDARDS**  
**TEMPORARY**  
**ENTRANCE INSTALLATION**  
**SINGLE RESIDENCE**

# UTS 2

ISSUE DATE: 06/05

# INSTALLATION REQUIREMENTS FOR UNDERGROUND SERVICE

USE 1 - 2  
USE 1 - 3  
USE 1 - 4

**MATERIALS FURNISHED AND INSTALLED BY MEMBER**

USE 3" CONDUIT FOR 200 AMP SERVICE AND 4" FOR SERVICES GREATER THAN 200 AMPS

- ① **3" OR 4" CONDUIT**  
SCHEDULE 80 PVC.
- ② **3" OR 4" 90°, 36" RADIUS SWEEP**  
(SEE NOTE 5)
- ③ **3" OR 4" ADAPTER**  
(IF NEEDED)
- ④ **3" OR 4" CONDUIT**  
SCHEDULE 40 PVC
- ⑤ **RED CAUTION RIBBON**  
6" WIDE CAUTION RIBBON, MUST SAY "ELECTRICAL LINE BURIED BELOW".
- ⑥ **1/4" POLYPROPYLENE STRING**  
INSTALLED IN ALL CONDUITS WITH STRING EXPOSED AND TIED OFF AT ENDS THRU CAPS AT END OF CONDUIT.

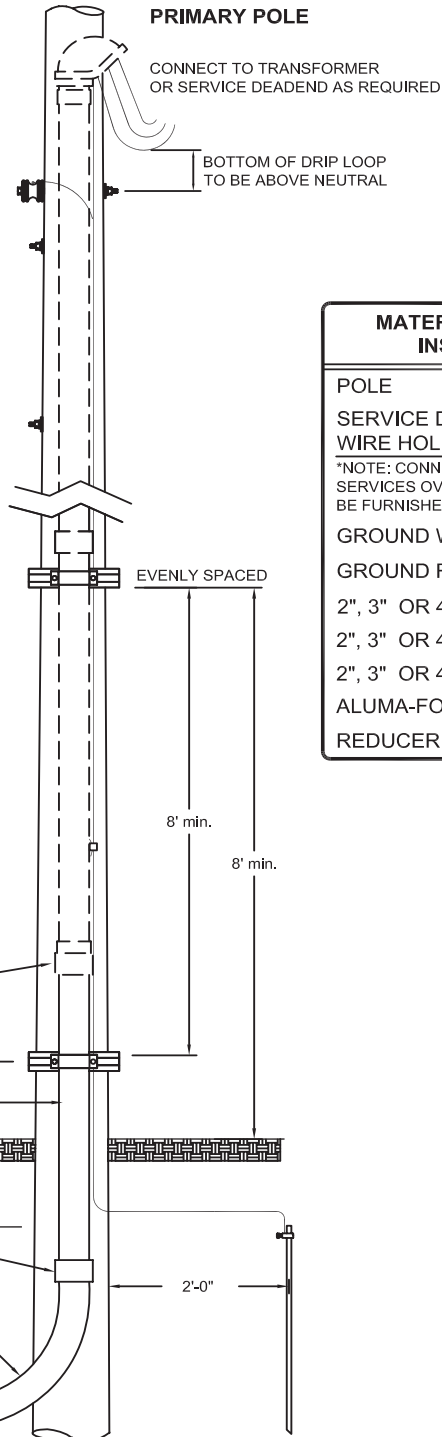

**MATERIALS FURNISHED AND INSTALLED BY NHEC**

**POLE**

**SERVICE DROP CONDUCTORS, WIRE HOLDER & CONNECTORS\***

\*NOTE: CONNECTORS FOR SERVICES OVER 500 MCM, WILL BE FURNISHED BY CONSUMER.

**GROUND WIRE**

**GROUND ROD AND CONNECTOR**

2", 3" OR 4" WEATHER HEAD

2", 3" OR 4" CONDUIT

2", 3" OR 4" COUPLING

ALUMA-FORM STANDOFF BRACKETS

REDUCER TO 2" OR 3"

**STANDOFF BRACKET IMPORTANT NOTES:**

CONTRACTOR TO KEEP CONDUIT TO 7-1/2" FROM FACE OF POLE.

NHEC PERSONNEL WILL PROVIDE A STANDOFF BRACKET TO ASSIST STEEL SWEEP DISTANCE TO THE POLE.

**ALL CONDUIT ABOVE GRADE TO BE SCHEDULE 80 PVC.**

**ASSEMBLY FOR USING STANDOFF BRACKET**

2" CONDUIT: USE 1 - 2

3" CONDUIT: USE 1 - 3

4" CONDUIT: USE 1 - 4

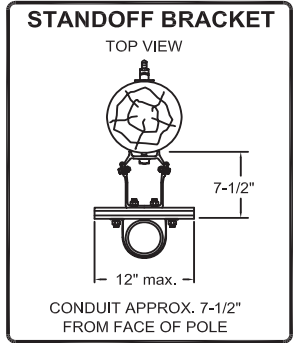

- NOTES:**
- 1.) ALL CONDUIT AND ACCESSORIES MUST MEET ELECTRICAL GRADE SPECIFICATIONS.
  - 2.) ALL MEMBER FURNISHED MATERIAL TO BE ON HAND, AND ALL NECESSARY EXCAVATION AND CONDUIT READY PRIOR TO TIME OF INSTALLATION OF EQUIPMENT ON POLE BY NHEC PERSONNEL.
  - 3.) CONDUIT TO BE ON QUADRANT OF POLE OPPOSITE FLOW OF TRAFFIC.
  - 4.) REFER TO SECTION 2 FOR FURTHER CLARIFICATION AND DETAILED DESCRIPTIONS FOR UNDERGROUND INSTALLATIONS.



**CONSTRUCTION STANDARDS**

SINGLE RESIDENCE

400 AMP SERVICE OR LESS

PRIMARY POLE WITH OFFSET

USE 1 - 2  
USE 1 - 3  
USE 1 - 4

ISSUE DATE: 10/10



# INSTALLATION REQUIREMENTS FOR UNDERGROUND SERVICE

USE 2 - 2C  
 USE 2 - 3C  
 USE 2 - 4C

**MATERIALS FURNISHED AND INSTALLED BY MEMBER**

USE 3" CONDUIT FOR 200 AMP SERVICE AND 4" FOR SERVICES GREATER THAN 200 AMPS

- ① **3" OR 4" CONDUIT**  
SCHEDULE 80 PVC.
- ② **3" OR 4" 90°, 36" RADIUS SWEEP**  
(SEE NOTE 5)
- ③ **3" OR 4" ADAPTER**  
(IF NEEDED)
- ④ **3" OR 4" CONDUIT**  
SCHEDULE 40 PVC
- ⑤ **RED CAUTION RIBBON**  
6" WIDE CAUTION RIBBON. MUST SAY "ELECTRICAL LINE BURIED BELOW".
- ⑥ **1/4" POLYPROPYLENE STRING**  
INSTALLED IN ALL CONDUITS WITH STRING EXPOSED AND TIED OFF AT ENDS THRU CAPS AT END OF CONDUIT.

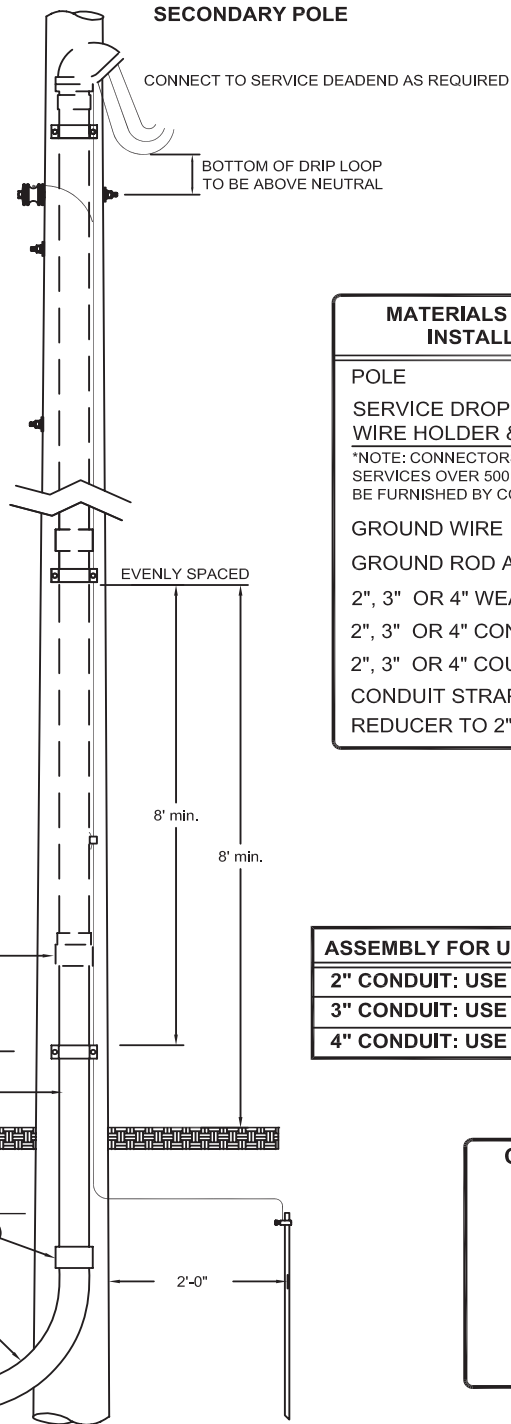

**MATERIALS FURNISHED AND INSTALLED BY NHEC**

POLE

SERVICE DROP CONDUCTORS, WIRE HOLDER & CONNECTORS\*

\*NOTE: CONNECTORS FOR SERVICES OVER 500 MCM. WILL BE FURNISHED BY CONSUMER.

GROUND WIRE

GROUND ROD AND CONNECTOR

2", 3" OR 4" WEATHER HEAD

2", 3" OR 4" CONDUIT

2", 3" OR 4" COUPLING

CONDUIT STRAPS

REDUCER TO 2" OR 3"

ASSEMBLY FOR USING CONDUIT CLIPS	
2" CONDUIT:	USE 2 - 2C
3" CONDUIT:	USE 2 - 3C
4" CONDUIT:	USE 2 - 4C

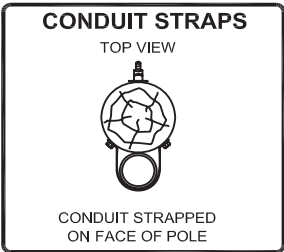

ALL CONDUIT ABOVE GRADE TO BE SCHEDULE 80 PVC.

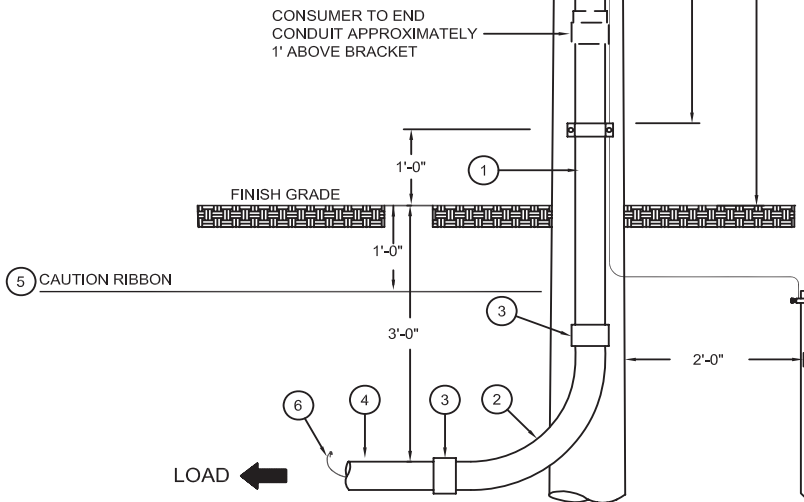

**NOTES:**

- 1.) ALL CONDUIT AND ACCESSORIES MUST MEET ELECTRICAL GRADE SPECIFICATIONS.
- 2.) ALL MEMBER FURNISHED MATERIAL TO BE ON HAND, AND ALL NECESSARY EXCAVATION AND CONDUIT READY PRIOR TO TIME OF INSTALLATION OF EQUIPMENT ON POLE BY NHEC PERSONNEL.
- 3.) CONDUIT TO BE ON QUADRANT OF POLE OPPOSITE FLOW OF TRAFFIC.
- 4.) REFER TO SECTION 2 FOR FURTHER CLARIFICATION AND DETAILED DESCRIPTIONS FOR UNDERGROUND INSTALLATIONS.



**CONSTRUCTION STANDARDS**  
 SINGLE RESIDENCE  
 400 AMP SERVICE OR LESS  
 SECONDARY POLE WITH CLIPS

USE 2 - 2C  
 USE 2 - 3C  
 USE 2 - 4C

ISSUE DATE: 10/10

**MATERIALS FURNISHED AND INSTALLED BY MEMBER**

- ① **3" OR 4" CONDUIT**  
CONDUIT MAY BE EITHER SCHEDULE 80 PVC OR GALVANIZED STEEL & INSULATED BUSHING.
- ② **PIPE STRAPS**
- ③ **3" OR 4" SLIP JOINT**  
FROST HEAVE PROTECTION INSTALLED ABOVE GRADE
- ④ **3" OR 4" CONDUIT (IF NEEDED)**  
SCHEDULE 40 PVC. BELOW FINISH GRADE.
- ⑤ **3" OR 4" 90°, 36" RADIUS SWEEP**
- ⑥ **3" OR 4" ADAPTER (IF NEEDED)**
- ⑦ **GROUND WIRE**  
AS REQUIRED BY NEC
- ⑧ **GROUND ROD CONNECTORS**
- ⑨ **GROUND RODS**  
(2) MIN. 8'-0" x 5/8" DIAMETER COPPER CLAD.
- ⑩ **METER SOCKET**  
SOCKET MUST HAVE INTEGRATED MAIN CIRCUIT BREAKER(S). TO BE SECURELY ATTACHED TO BUILDING BY CONSUMER.
- ⑪ **RED CAUTION RIBBON**  
6" WIDE CAUTION RIBBON. MUST SAY "ELECTRICAL LINE BURIED BELOW".
- ⑫ **1/4" POLYPROPYLENE STRING**  
INSTALLED IN ALL CONDUITS WITH STRING EXPOSED AND TIED OFF AT ENDS THRU CAPS AT END OF CONDUIT.

**MATERIALS FURNISHED AND INSTALLED BY NHEC**

- METER**
- UNDERGROUND SERVICE LATERAL CONDUCTORS**  
FURNISHED AND INSTALLED BY COOPERATIVE FOR BASIC SERVICE;  
FURNISHED BY CONSUMER FOR LARGE BASIC SERVICE.

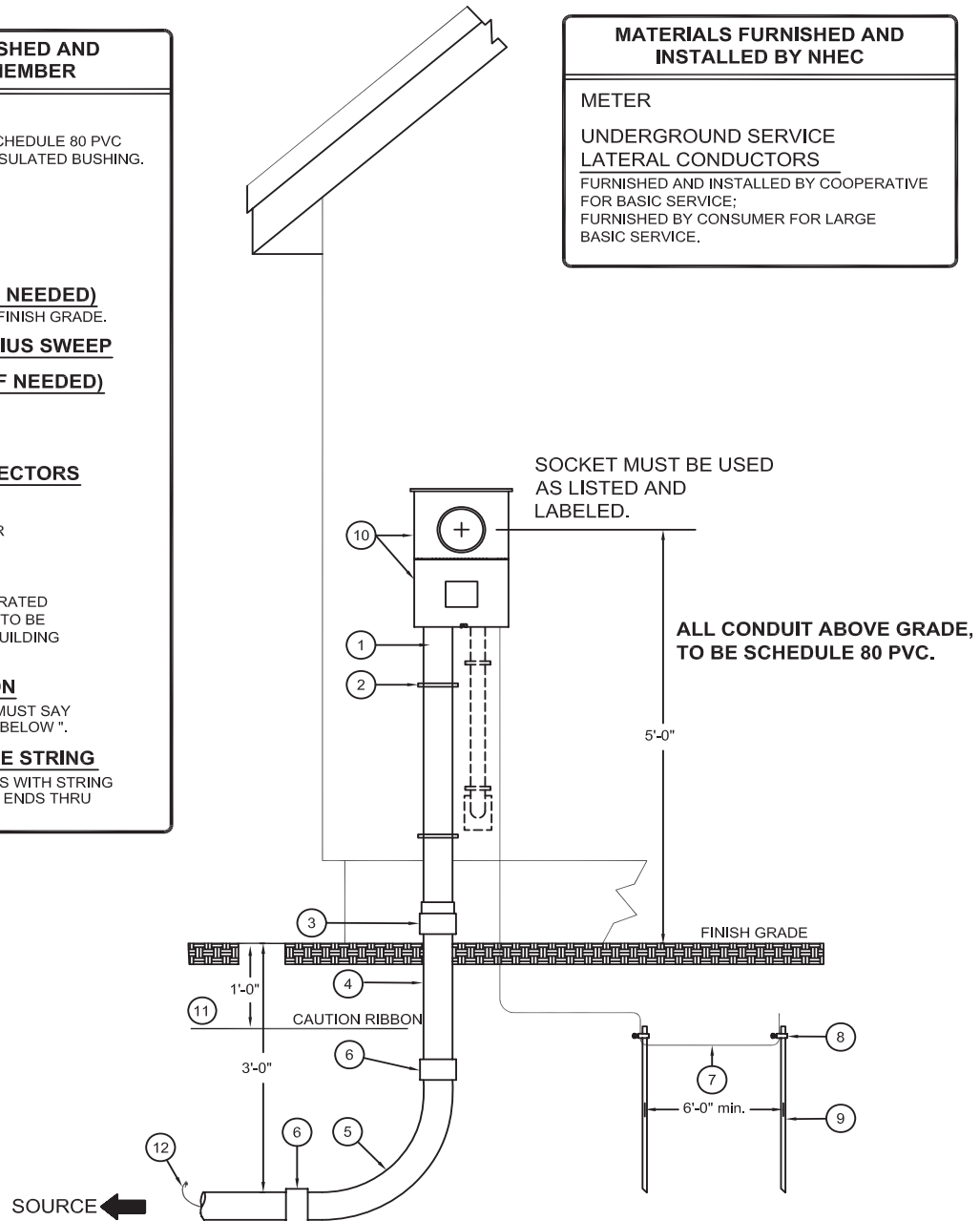

**NOTES:**

- 1.) PLEASE CALL NHEC AND MAKE ARRANGEMENTS TO HAVE THE METER LOCATION APPROVED BEFORE MAKING ANY CHANGES IN YOUR PRESENT ENTRANCE OR INSTALLING A NEW ENTRANCE.
- 2.) ALL SERVICE ENTRANCE WIRING MUST BE COMPLETE AND ALL NECESSARY EXCAVATION AND CONDUIT READY PRIOR TO THE TIME OF INSTALLATION OF THE UNDERGROUND SERVICE LATERAL CONDUCTORS BY NHEC.
- 3.) IF A REDUCTION IN CONDUIT SIZE IS REQUIRED SEE IU SERVICE REDUCTION.
- 4.) FOUR WIRE CABLE MUST BE INSTALLED FROM METER SOCKET TO DISTRIBUTION PANEL.
- 5.) REFER TO SECTION 2 FOR FURTHER CLARIFICATION AND DETAILED DESCRIPTIONS FOR UNDERGROUND INSTALLATIONS.



**CONSTRUCTION STANDARDS**

**ENTRANCE INSTALLATION  
SINGLE RESIDENCE**

**USE 3**

ISSUE DATE: 06/05

**MATERIALS FURNISHED AND INSTALLED BY MEMBER**

- ① **SUPPORT POST** (PRESERVATIVE TREATED)  
6" x 6" MIN. SQUARE OR 8" DIA. MIN. ROUND.
- ② **PIPE STRAPS**
- ③ **3" OR 4" CONDUIT**  
SCHEDULE 80 PVC
- ④ **3" OR 4" SLIP JOINT**  
FROST HEAVE PROTECTION  
INSTALLED ABOVE GRADE
- ⑤ **3" OR 4" CONDUIT (IF NEEDED)**  
SCHEDULE 80 PVC.
- ⑥ **3" OR 4" 90°, 36" RADIUS SWEEP**
- ⑦ **3" OR 4" ADAPTER (IF NEEDED)**
- ⑧ **GROUND WIRE**  
AS REQUIRED BY N.E.C.
- ⑨ **GROUND ROD CONNECTORS**
- ⑩ **GROUND RODS**  
(2) MIN. 8'-0" x 5/8" DIAMETER  
COPPER CLAD.
- ⑪ **METER SOCKET**  
SOCKET MUST HAVE INTEGRATED  
MAIN CIRCUIT BREAKER(S). TO BE  
SECURELY ATTACHED TO POST  
BY CONSUMER.
- ⑫ **RED CAUTION RIBBON**  
6" WIDE CAUTION RIBBON. MUST SAY  
"ELECTRICAL LINE BURIED BELOW".
- ⑬ **1/4" POLYPROPYLENE STRING**  
INSTALLED IN ALL CONDUITS WITH STRING  
EXPOSED AND TIED OFF AT ENDS THRU  
CAPS AT END OF CONDUIT.

**MATERIALS FURNISHED AND INSTALLED BY NHEC**

**METER**  
**UNDERGROUND SERVICE LATERAL CONDUCTORS** (TRANSFORMER TO METER)  
FURNISHED AND INSTALLED BY COOPERATIVE  
FOR BASIC SERVICE;  
FURNISHED BY CONSUMER FOR LARGE  
BASIC SERVICE.

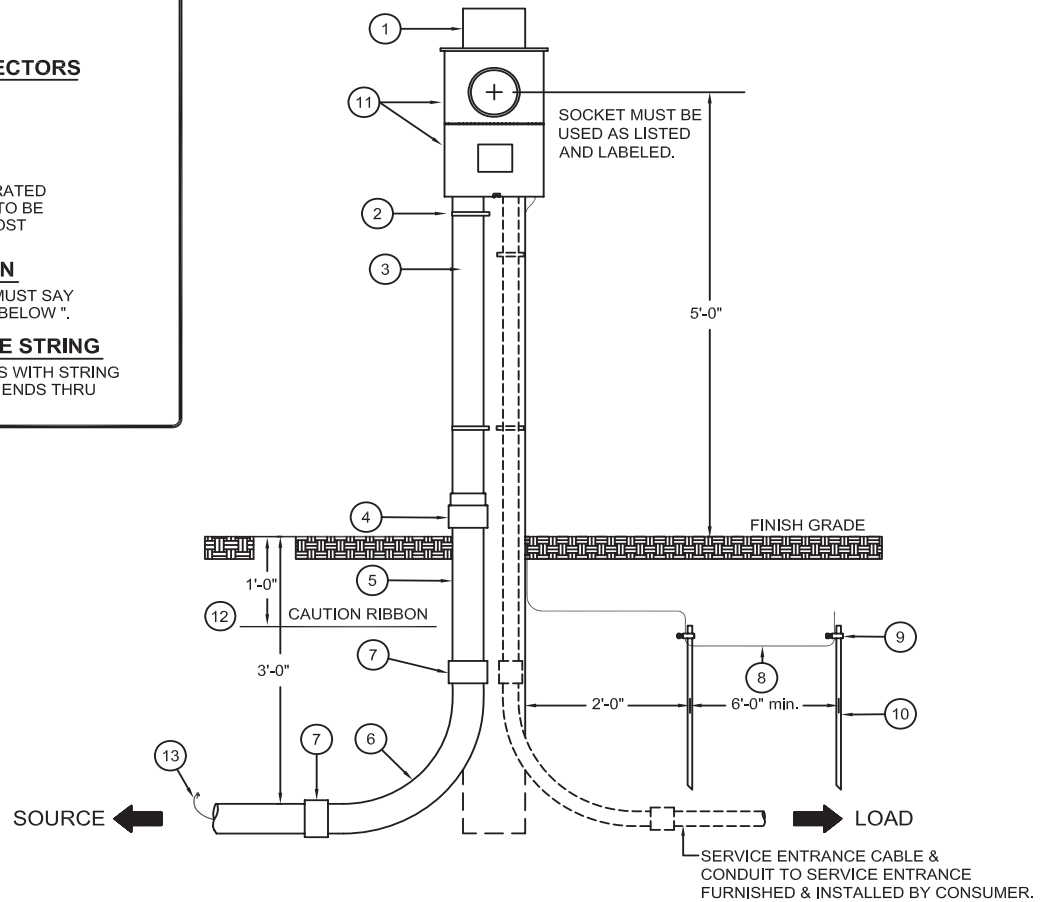

**NOTES:**

- 1.) PLEASE CALL NHEC AND MAKE ARRANGEMENTS TO HAVE THE METER LOCATION APPROVED BEFORE MAKING ANY CHANGES IN YOUR PRESENT ENTRANCE OR INSTALLING A NEW ENTRANCE.
- 2.) MOBILE HOME METER LOCATION SHALL BE READILY ACCESSIBLE, IN SIGHT, AND NOT MORE THAN 30 FEET FROM EXTERIOR WALL OF MOBILE HOME IT SERVES. IF DISTANCE EXCEEDS 30 FEET, A SECOND DISCONNECT SWITCH IS REQUIRED.
- 3.) ALL SERVICE ENTRANCE WIRING MUST BE COMPLETE AND ALL NECESSARY EXCAVATION AND CONDUIT READY PRIOR TO THE TIME OF INSTALLATION OF THE UNDERGROUND SERVICE LATERAL CONDUCTORS BY NHEC.
- 4.) FOUR WIRE CABLE MUST BE INSTALLED FROM METER SOCKET TO DISTRIBUTION PANEL.
- 5.) REFER TO SECTION 2 FOR FURTHER CLARIFICATION AND DETAILED DESCRIPTIONS FOR UNDERGROUND INSTALLATIONS.



**CONSTRUCTION STANDARDS**  
**REMOTE METER LOCATION**  
**ENTRANCE INSTALLATION**  
**SINGLE RESIDENCE**

**USE 4**

ISSUE DATE: 06/05

- MATERIALS FURNISHED AND INSTALLED BY MEMBER**
- ① **4" CONDUIT**  
SCHEDULE 80 PVC
  - ② **4" 90°, 36" RADIUS SWEEP**  
GALVANIZED STEEL
  - ③ **4" ADAPTER**  
(IF NEEDED)
  - ④ **4" CONDUIT**  
SCHEDULE 40 PVC
  - ⑤ **1/4" POLYPROPYLENE STRING**  
INSTALLED IN ALL CONDUITS WITH STRING EXPOSED AND TIED OFF AT ENDS THRU CAPS AT END OF CONDUIT.
  - ⑥ **#6 SOLID BARE GROUND WIRE**
  - ⑦ **RED CAUTION RIBBON**  
6" WIDE CAUTION RIBBON. MUST SAY "ELECTRICAL LINE BURIED BELOW".

- MATERIALS FURNISHED AND INSTALLED BY NHEC**
- POLE
  - GROUND ROD AND CONNECTOR
  - ALUMA-FORM STANDOFF BRACKETS

**STANDOFF BRACKET IMPORTANT NOTES:**

CONTRACTOR TO KEEP CONDUIT TO 7-1/2" FROM FACE OF POLE.

NHEC PERSONNEL WILL PROVIDE A STANDOFF BRACKET TO ASSIST STEEL SWEEP DISTANCE TO THE POLE.

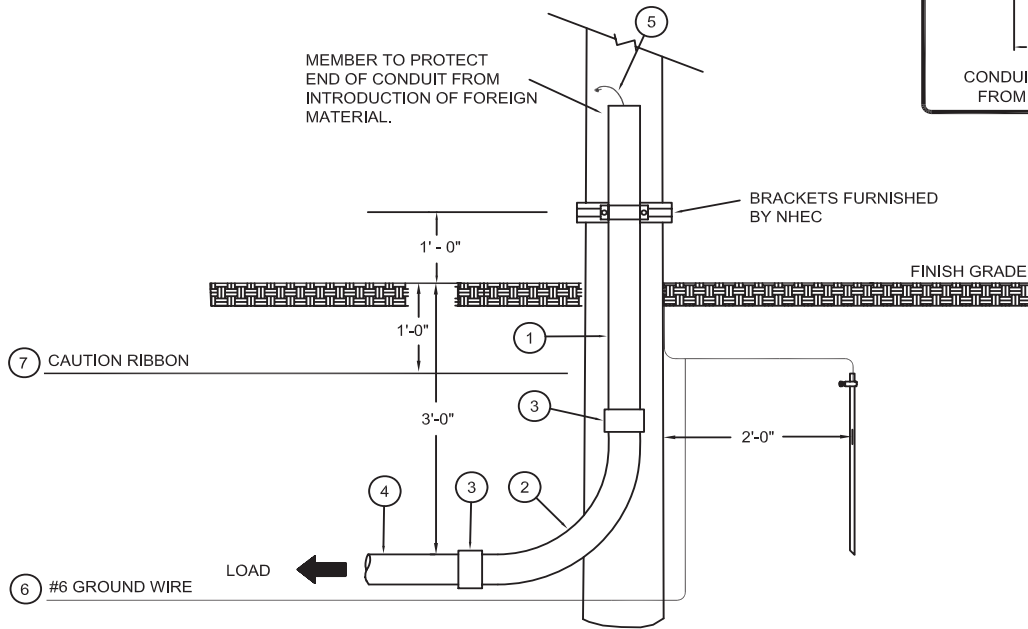
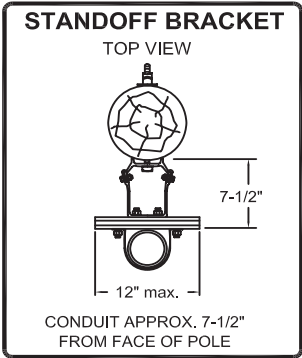

**NOTES:**

- 1.) ALL CONSUMER FURNISHED MATERIAL TO BE ON HAND, AND ALL NECESSARY EXCAVATION AND CONDUIT READY PRIOR TO TIME OF INSTALLATION OF EQUIPMENT ON POLE BY NHEC PERSONNEL.
- 2.) CONDUIT TO BE ON QUADRANT OF POLE OPPOSITE FLOW OF TRAFFIC.
- 3.) REFER TO SECTION 2 FOR FURTHER CLARIFICATION AND DETAILED DESCRIPTIONS FOR UNDERGROUND INSTALLATIONS.



**CONSTRUCTION STANDARDS**  
UNDERGROUND PRIMARY  
RADIAL FEED - SINGLE TRANSFORMER  
PRIMARY POLE MATERIALS

URD 1A

ISSUE DATE: 06/05

MATERIALS FURNISHED AND INSTALLED BY MEMBER	
①	<b>4" CONDUIT</b> SCHEDULE 80 PVC
②	<b>4" 90°, 36" RADIUS SWEEP</b> GALVANIZED STEEL
③	<b>4" ADAPTER</b> (IF NEEDED)
④	<b>4" CONDUIT</b> SCHEDULE 40 PVC
⑤	<b>CONDUIT END CAPS</b>
⑥	<b>1/4" POLYPROPYLENE STRING</b> INSTALLED IN ALL CONDUITS WITH STRING EXPOSED AND TIED OFF AT ENDS THRU CAPS AT END OF CONDUIT.
⑦	<b>#6 SOLID BARE GROUND WIRE</b>
⑧	<b>RED CAUTION RIBBON</b> 6" WIDE CAUTION RIBBON. MUST SAY " ELECTRICAL LINE BURIED BELOW ".

MATERIALS FURNISHED AND INSTALLED BY NHEC
POLE
GROUND ROD AND CONNECTOR
ALUMA-FORM STANDOFF BRACKETS

**STANDOFF BRACKET IMPORTANT NOTES:**

CONTRACTOR TO KEEP CONDUIT TO 7-1/2" FROM FACE OF POLE.

NHEC PERSONNEL WILL PROVIDE A STANDOFF BRACKET TO ASSIST STEEL SWEEP DISTANCE TO THE POLE.

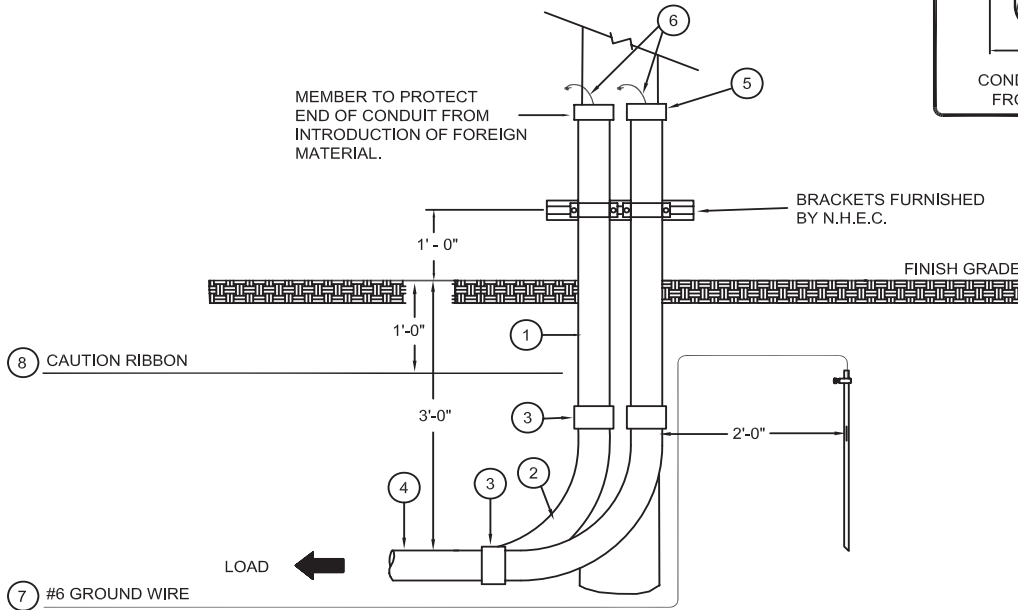
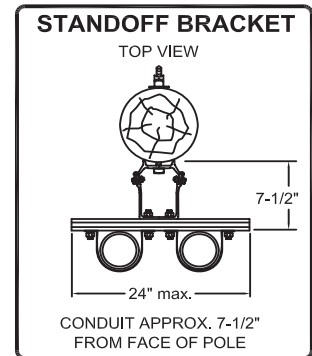

**NOTES:**

- 1.) ALL CONSUMER FURNISHED MATERIAL TO BE ON HAND, AND ALL NECESSARY EXCAVATION AND CONDUIT READY PRIOR TO TIME OF INSTALLATION OF EQUIPMENT ON POLE BY NHEC PERSONNEL.
- 2.) CONDUIT TO BE ON QUADRANT OF POLE OPPOSITE FLOW OF TRAFFIC.
- 3.) REFER TO SECTION 2 FOR FURTHER CLARIFICATION AND DETAILED DESCRIPTIONS FOR UNDERGROUND INSTALLATIONS.



CONSTRUCTION STANDARDS  
 UNDERGROUND PRIMARY  
 LOOP FEED - MULTIPLE TRANSFORMERS  
 PRIMARY POLE MATERIALS

URD 1B

ISSUE DATE: 06/05

BACKFILL AROUND VAULT MUST BE FLAT AND LEVEL FOR A MINIMUM WIDTH OF 3 FT. ON ALL SIDES.

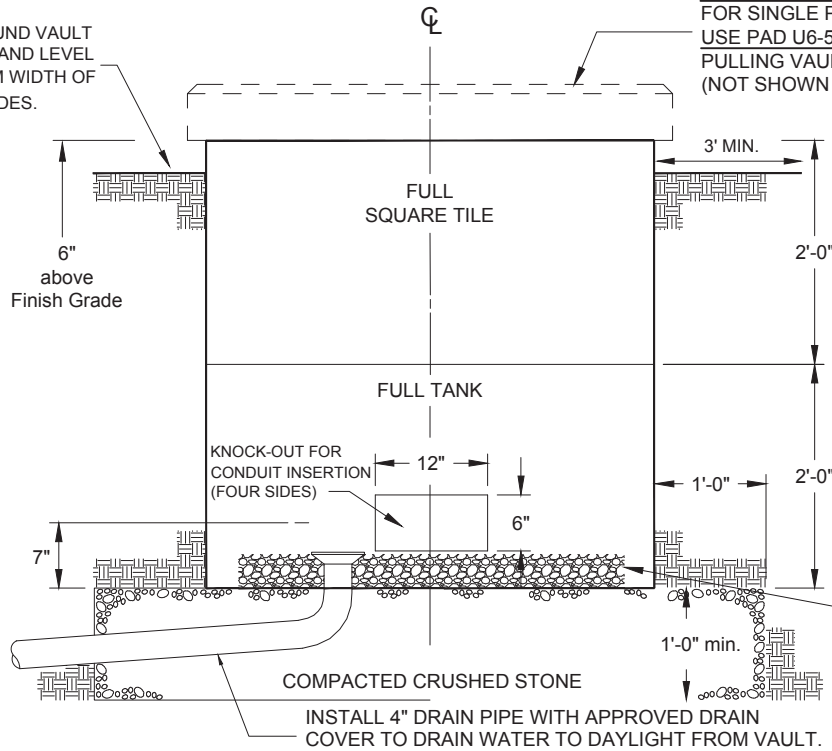

**PAD & COVER REQUIREMENTS**  
 FOR SINGLE PHASE TRANSFORMERS  
 USE PAD U6-5A AND WHEN USED AS A  
 PULLING VAULT USE COVER U7-5B.  
 (NOT SHOWN IN TOP VIEW)

PROVIDE 3" OF CRUSHED STONE ON TOP OF COMPACTED CRUSHED STONE IN BOTTOM OF VAULT.

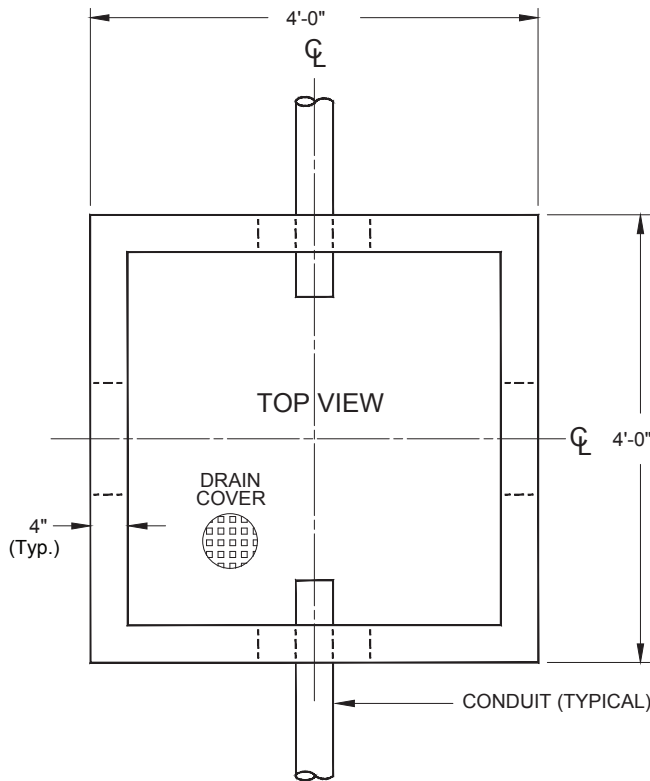

### INSTALLATION REQUIREMENTS

- 1.) IF THE VAULT IS CUT INTO AN EMBANKMENT, NHEC MAY REQUIRE A RETAINING WALL EITHER IN FRONT OR BEHIND THE VAULT TO PREVENT MATERIAL FROM SPILLING INTO OR AWAY FROM THE VAULT.
- 2.) TOP OF VAULT SHALL BE SIX INCHES ABOVE FINISHED GRADE.
- 3.) ALL VAULTS WILL BE CONSTRUCTED WITH A DRAINAGE SYSTEM OF APPROVED PIPE MATERIAL TO DRAIN WATER THAT MAY PENETRATE THE VAULT. THE PIPING SHALL ORIGINATE AT THE LOWEST POINT INSIDE THE VAULT AND BE ROUTED TO FREE AIR AT AN ELEVATION BELOW ITS ORIGIN THAT PROMOTES DRAINAGE..
- 4.) IF VAULT IS LOCATED NEAR THE TRAVELED WAY, NHEC MAY REQUIRE A PROTECTIVE STRUCTURE TO PREVENT DAMAGE.
- 5.) SEAL ALL KNOCKOUTS AFTER CONDUIT IS PLACED.
- 6.) CONCRETE SHALL HAVE A COMPRESSIVE STRENGTH OF 5000 P.S.I. AFTER 28 DAYS WHEN TESTED IN ACCORDANCE WITH ASTM C-39-72(LATEST EDITION).
- 7.) REFER TO MEMBER HANDBOOK SECTION 2 OR CONSTRUCTION STANDARDS TAB 12 FOR FURTHER CLARIFICATION AND DETAILED DESCRIPTIONS FOR UNDERGROUND INSTALLATIONS.

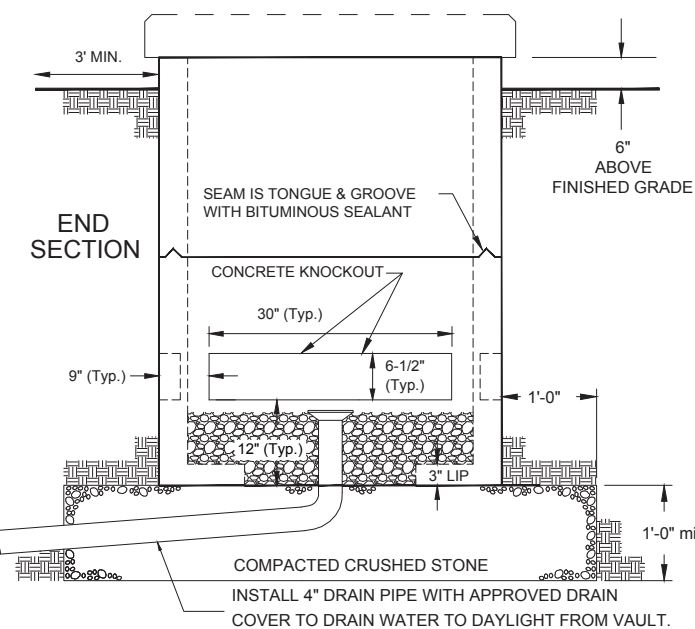
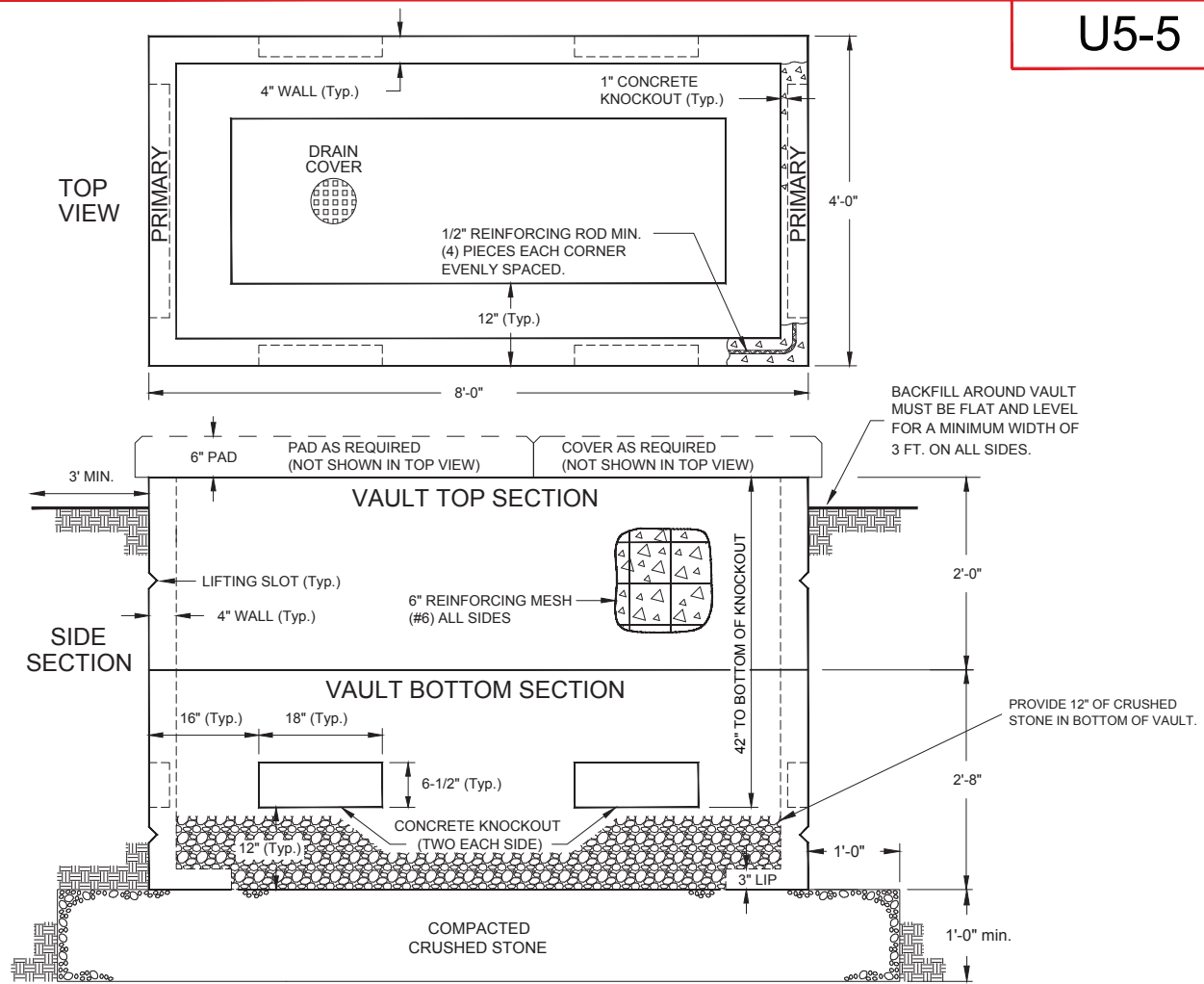

**INSTALLATION REQUIREMENTS**

- 1.) IF THE VAULT IS CUT INTO AN EMBANKMENT, NHEC MAY REQUIRE A RETAINING WALL EITHER IN FRONT OR BEHIND THE VAULT TO PREVENT MATERIAL FROM SPILLING INTO OR AWAY FROM THE VAULT.
- 2.) TOP OF VAULT SHALL BE SIX INCHES ABOVE FINISHED GRADE.
- 3.) ALL VAULTS WILL BE CONSTRUCTED WITH A DRAINAGE SYSTEM OF APPROVED PIPE MATERIAL TO DRAIN WATER THAT MAY PENETRATE THE VAULT. THE PIPING SHALL ORIGINATE AT THE LOWEST POINT INSIDE THE VAULT AND BE ROUTED TO FREE AIR AT AN ELEVATION BELOW ITS ORIGATION THAT PROMOTES DRAINAGE.
- 4.) IF VAULT IS LOCATED NEAR THE TRAVELED WAY, NHEC MAY REQUIRE A PROTECTIVE STRUCTURE TO PREVENT DAMAGE.
- 5.) SEAL ALL KNOCKOUTS AFTER CONDUIT IS PLACED.
- 6.) CONCRETE SHALL HAVE A COMPRESSIVE STRENGTH OF 5000 P.S.I. AFTER 28 DAYS WHEN TESTED IN ACCORDANCE WITH ASTM C-39-72 (LATEST EDITION).
- 7.) REFER TO MEMBER HANDBOOK SECTION 2 OR CONSTRUCTION STANDARDS TAB 12 FOR FURTHER CLARIFICATION AND DETAILED DESCRIPTIONS FOR UNDERGROUND INSTALLATIONS.

**PAD & COVER REQUIREMENTS**

- 1.) FOR SINGLE PHASE 15 OR 25 KV TRANSFORMER (15-167 kVA), USE PAD U6-5A & COVER U7-5B.
- 2.) FOR SINGLE PHASE 15 OR 25 KV 200 AMP SECTIONALIZING CABINET USE PAD U6-5B & COVER U7-5B.
- 3.) FOR SPLICING OR PULLING VAULT USE COVER U7-5A & COVER U7-5B.



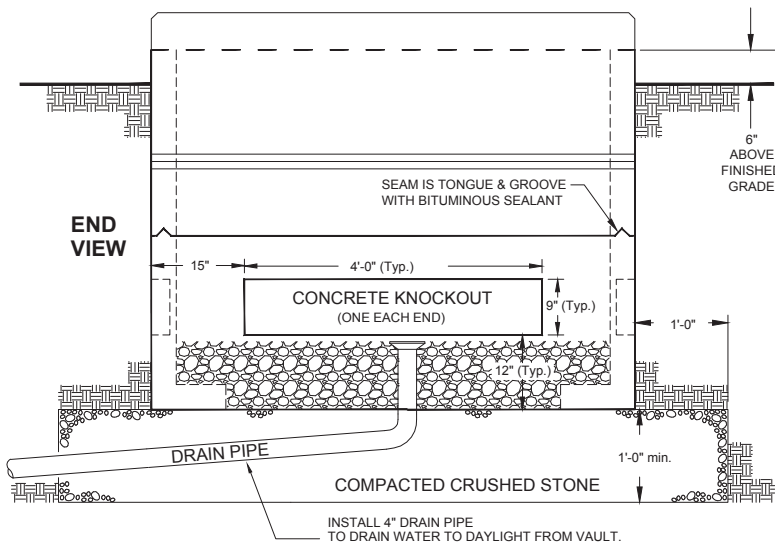
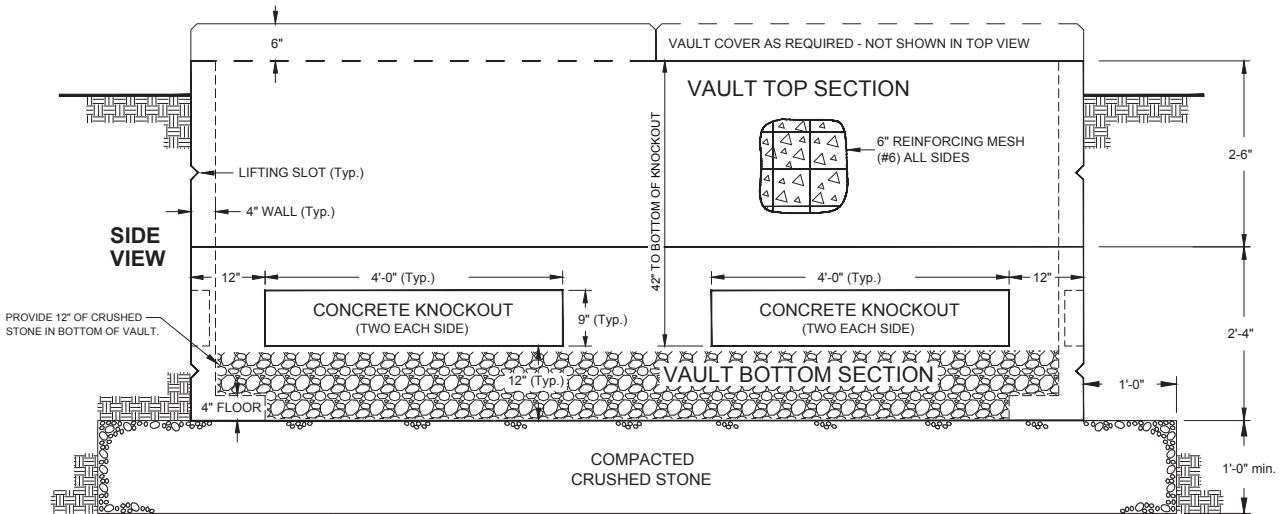
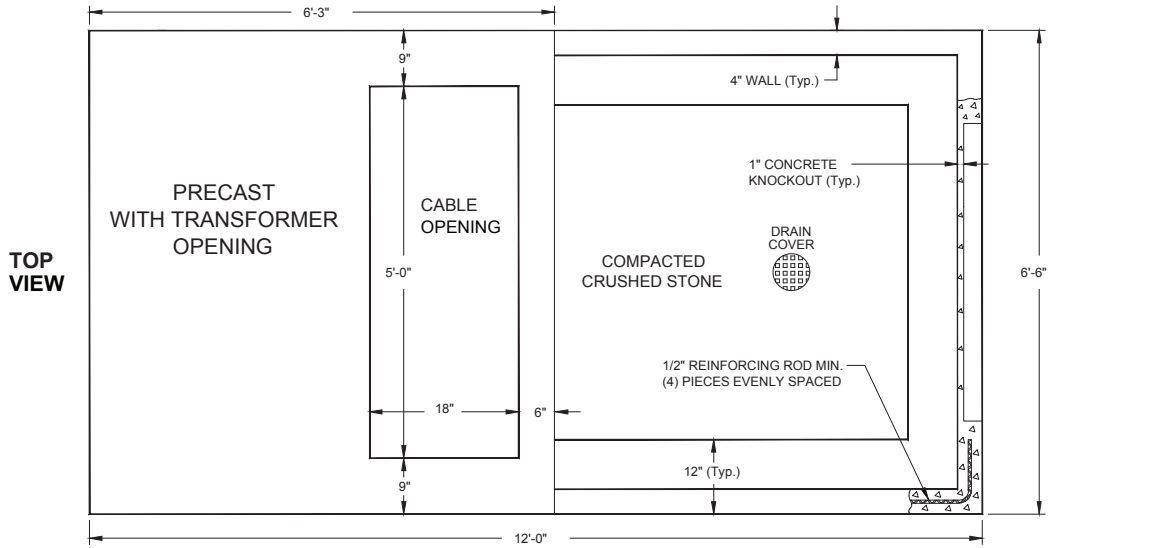

**INSTALLATION REQUIREMENTS**

- 1.) IF THE VAULT IS CUT INTO AN EMBANKMENT, NHEC MAY REQUIRE A RETAINING WALL EITHER IN FRONT OR BEHIND THE VAULT TO PREVENT MATERIAL FROM SPILLING INTO OR AWAY FROM THE VAULT.
- 2.) TOP OF UPPER SECTION OF VAULT SHALL BE SIX INCHES ABOVE FINISHED GRADE.
- 3.) ALL VAULTS WILL BE CONSTRUCTED WITH A DRAINAGE SYSTEM OF APPROVED PIPE MATERIAL TO DRAIN WATER THAT MAY PENETRATE THE VAULT. THE PIPING SHALL ORIGINATE AT THE LOWEST POINT INSIDE THE VAULT AND BE ROUTED TO FREE AIR AT AN ELEVATION BELOW ITS ORIGINATION THAT PROMOTES DRAINAGE.
- 4.) IF VAULT IS LOCATED NEAR THE TRAVELED WAY, NHEC MAY REQUIRE A PROTECTIVE STRUCTURE TO PREVENT DAMAGE.
- 5.) SEAL ALL KNOCKOUTS AFTER CONDUIT IS PLACED.
- 6.) CONCRETE SHALL HAVE A COMPRESSIVE STRENGTH OF 5000 P.S.I. AFTER 28 DAYS WHEN TESTED IN ACCORDANCE WITH ASTM C-39-72 (LATEST EDITION).
- 7.) REFER TO MEMBER HANDBOOK SECTION 2 OR CONSTRUCTION STANDARDS TAB 12 FOR FURTHER CLARIFICATION AND DETAILED DESCRIPTIONS FOR UNDERGROUND INSTALLATIONS.

**FURTHER REQUIREMENT INCLUDES:**

- 1.) VAULT COVER U7-7E TO ENCLOSE VAULT.
- 2.) APPROXIMATE WEIGHTS:
 

VAULT TOP SECTION	5600 LBS.
VAULT BOTTOM SECTION	5300 LBS.
VAULT COVER U7-7E	2600 LBS.



**CONSTRUCTION STANDARDS  
PRECAST VAULT ASSEMBLY  
FOR  
3-PHASE TRANSFORMERS**



# U5-7S

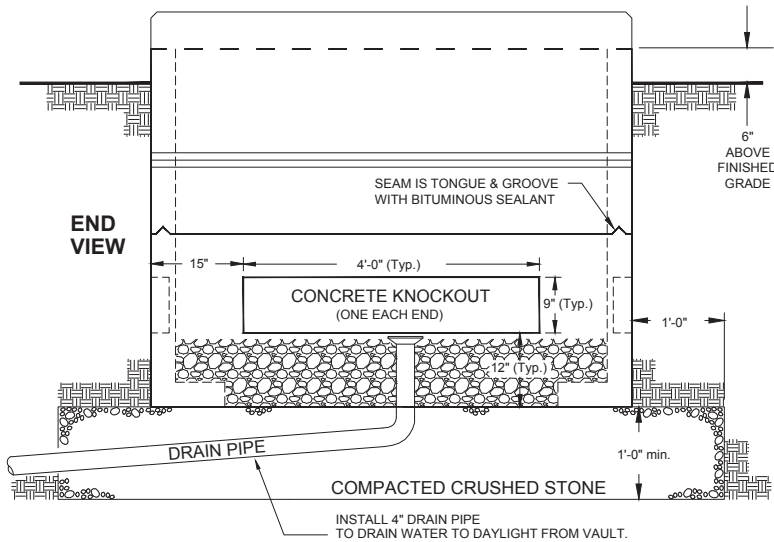
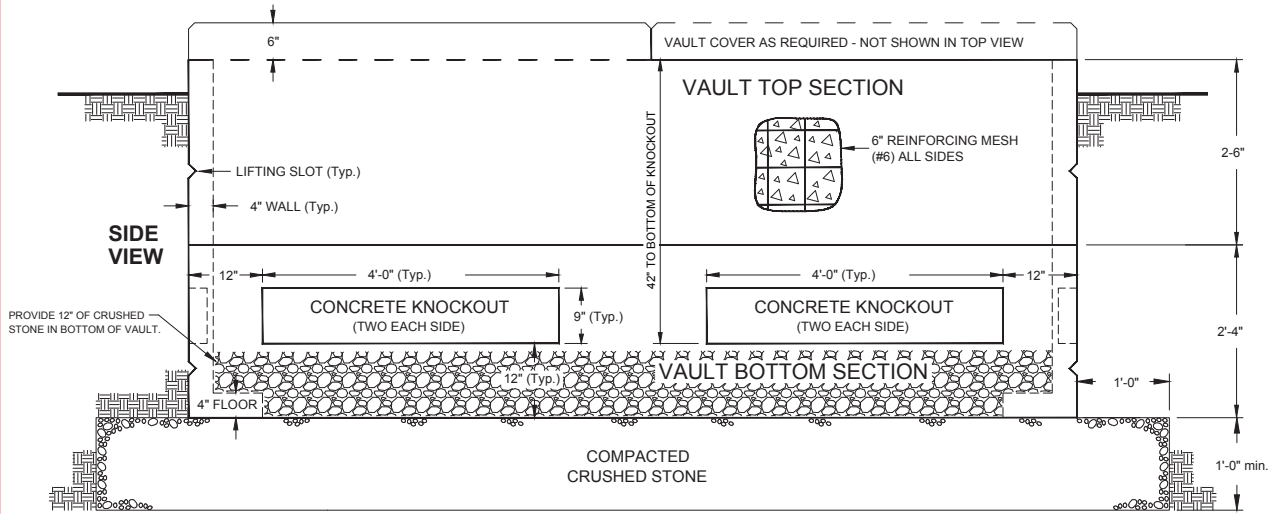
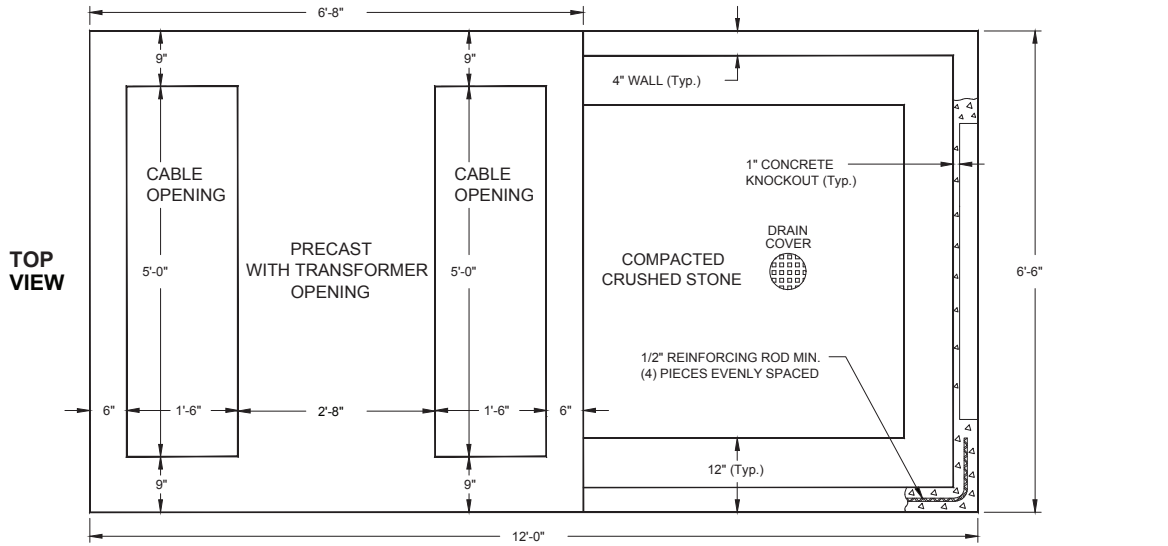

### INSTALLATION REQUIREMENTS

- 1.) IF THE VAULT IS CUT INTO AN EMBANKMENT, NHEC MAY REQUIRE A RETAINING WALL EITHER IN FRONT OR BEHIND THE VAULT TO PREVENT MATERIAL FROM SPILLING INTO OR AWAY FROM THE VAULT.
- 2.) TOP OF UPPER SECTION OF VAULT SHALL BE SIX INCHES ABOVE FINISHED GRADE.
- 3.) ALL VAULTS WILL BE CONSTRUCTED WITH A DRAINAGE SYSTEM OF APPROVED PIPE MATERIAL TO DRAIN WATER THAT MAY PENETRATE THE VAULT. THE PIPING SHALL ORIGINATE AT THE LOWEST POINT INSIDE THE VAULT AND BE ROUTED TO FREE AIR AT AN ELEVATION BELOW ITS ORIGIN THAT PROMOTES DRAINAGE.
- 4.) IF VAULT IS LOCATED NEAR THE TRAVELED WAY, NHEC MAY REQUIRE A PROTECTIVE STRUCTURE TO PREVENT DAMAGE.
- 5.) SEAL ALL KNOCKOUTS AFTER CONDUIT IS PLACED.
- 6.) CONCRETE SHALL HAVE A COMPRESSIVE STRENGTH OF 5000 P.S.I. AFTER 28 DAYS WHEN TESTED IN ACCORDANCE WITH ASTM C-39-72 (LATEST EDITION).
- 7.) REFER TO MEMBER HANDBOOK SECTION 2 OR CONSTRUCTION STANDARDS TAB 12 FOR FURTHER CLARIFICATION AND DETAILED DESCRIPTIONS FOR UNDERGROUND INSTALLATIONS.

### FURTHER REQUIREMENT INCLUDES:

- 1.) VAULT COVER U7-7E TO ENCLOSE VAULT.
- 2.) APPROXIMATE WEIGHTS:
  - VAULT TOP SECTION 5600 LBS.
  - VAULT BOTTOM SECTION 5300 LBS.
  - VAULT COVER U7-7E 2600 LBS.



**CONSTRUCTION STANDARDS**  
**PRECAST VAULT ASSEMBLY**  
 FOR  
**3-PHASE 600 AMP SECTIONALIZER**

# U5-7S

ISSUE DATE: 05/16

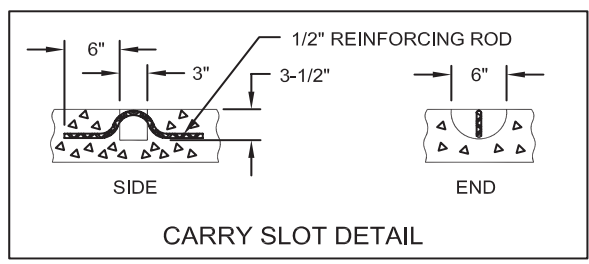
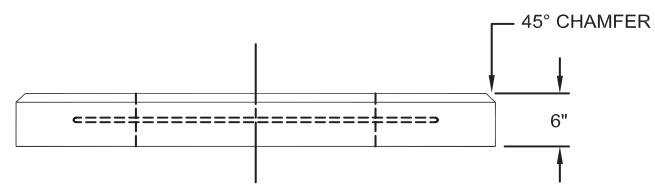
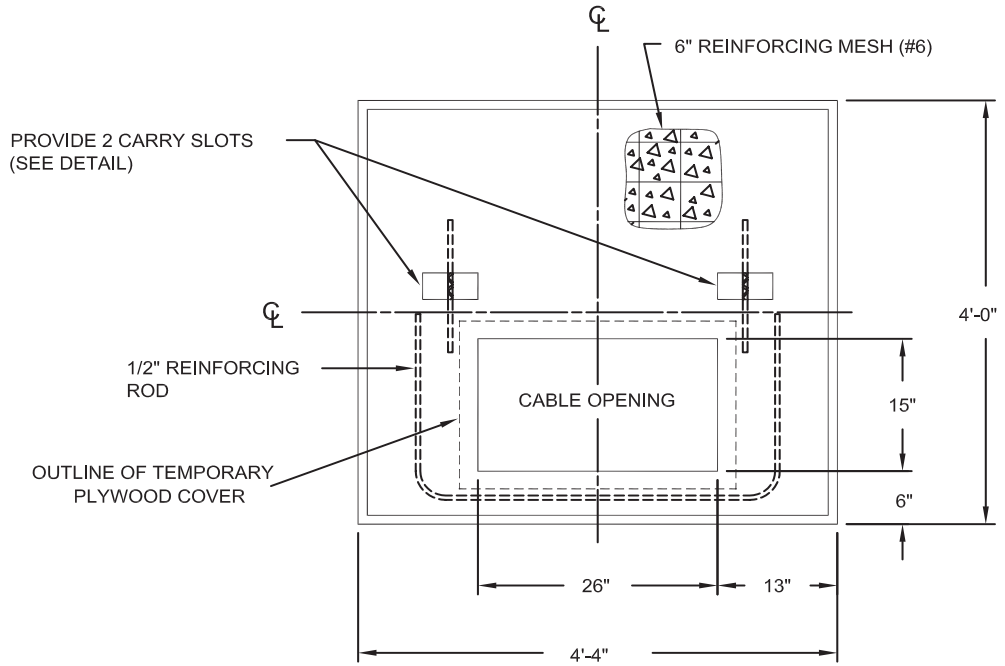

- NOTE:**
- 1.) CONCRETE SHALL HAVE A COMPRESSIVE STRENGTH OF 5000 P.S.I. AFTER 28 DAYS WHEN TESTED IN ACCORDANCE WITH ASTM C 39-72 (LATEST EDITION).
  - 2.) USE COVER U7-5B WITH VAULT U5-5.
  - 3.) CONTRACTOR IS RESPONSIBLE TO COVER CABLE OPENING UNTIL NHEC BEGINS WORK. SEE DRAWING BELOW FOR RECOMMENDED COVER ATTATCHMENT.

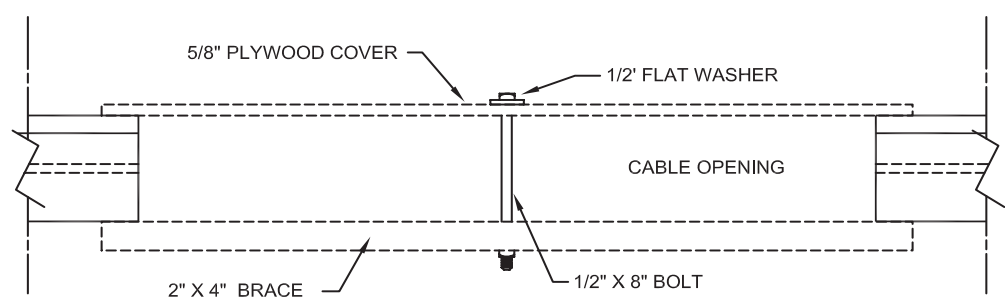

PARTIAL SECTION AT CABLE OPENING



CONSTRUCTION STANDARDS  
 SINGLE PHASE TRANSFORMER  
 VAULT PAD FOR U5-5 & U5-4  
 INCLUDING TEMPORARY CABLE OPENING COVER

U6-5A  
 ISSUE DATE: 01/06

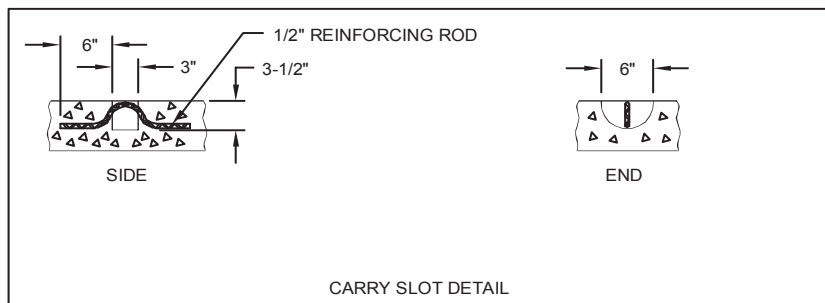
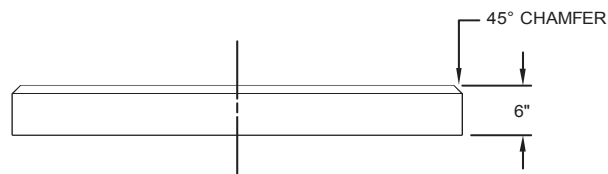
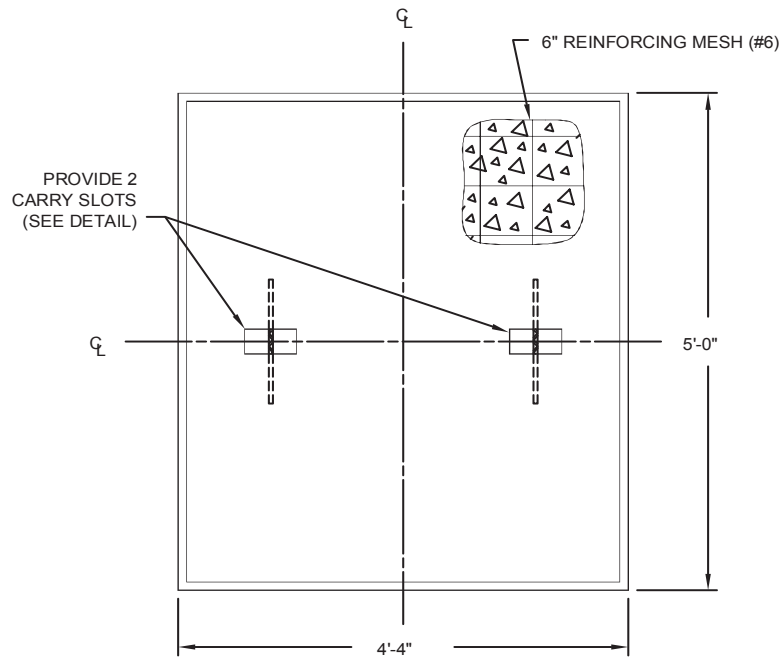

**NOTE:**

- 1.) CONCRETE SHALL HAVE A COMPRESSIVE STRENGTH OF 5000 P.S.I. AFTER 28 DAYS WHEN TESTED IN ACCORDANCE WITH ASTM C 39-72 (LATEST EDITION)
- 2.) APPROXIMATE WEIGHT: 1515 LBS.

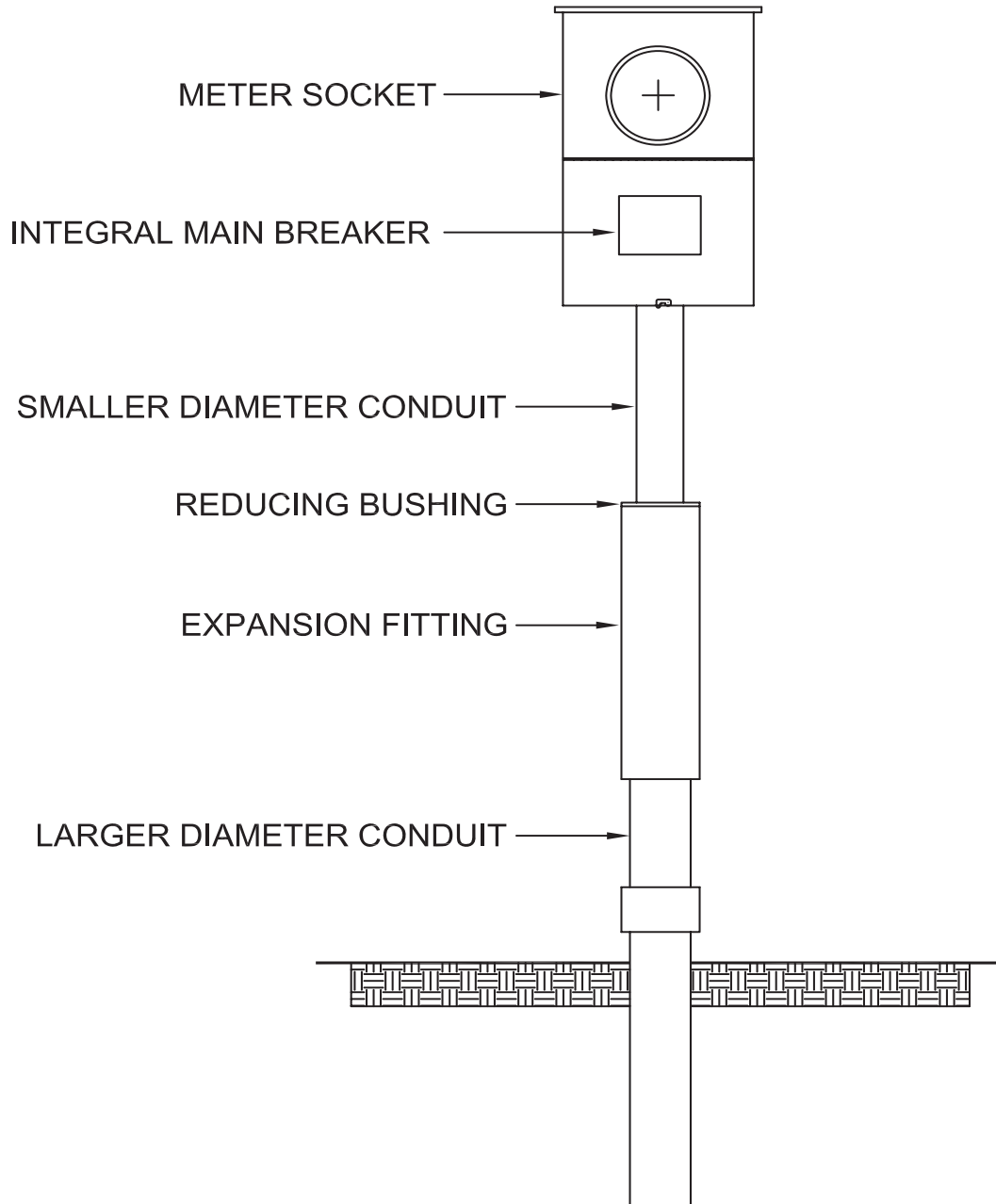

### ONE OR MORE PRIMARY CIRCUITS WITH TELEPHONE AND/OR CABLE TV

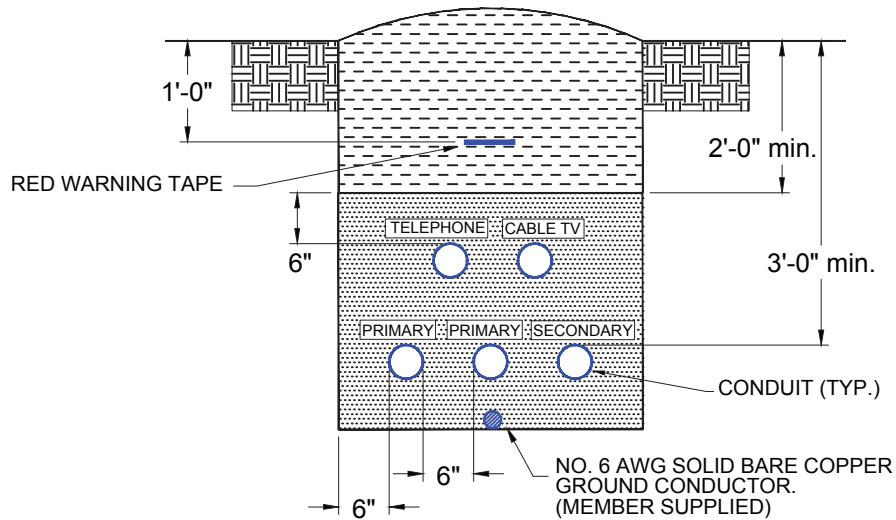

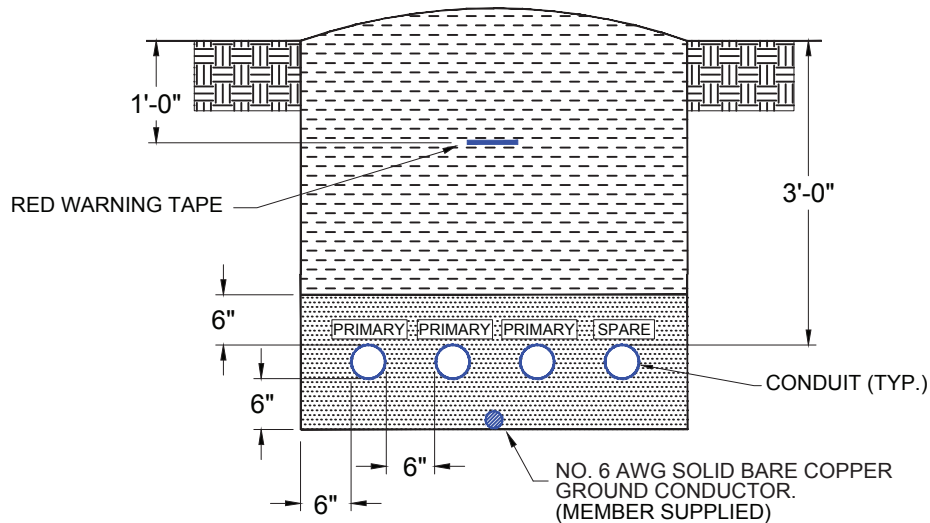

### PRIMARY CIRCUIT WITH SPARE



**NOTE:**

1. TRENCH WIDTH AS REQUIRED TO MAINTAIN 6" MINIMUM SPACING BETWEEN ALL CONDUITS AND TRENCH SIDEWALLS.
2. TRENCH TO BE INSPECTED BY A REPRESENTATIVE OF NHEC PRIOR TO BACKFILLING.
3. REFER TO MEMBER HANDBOOK SECTION 2 OR CONSTRUCTION STANDARDS TAB 12 FOR FURTHER CLARIFICATION AND DETAILED DESCRIPTIONS FOR UNDERGROUND INSTALLATIONS.

 <p>WHEEL COMPACTED BACKFILL, NO ROCKS LARGER THAN 6" DIAMETER</p>	 <p>SAND OR FINE BACKFILL, NO ROCKS LARGER THAN 1" DIAMETER</p>	 <p>UNDISTURBED EARTH</p>
---	--	--

# ONE OR MORE SECONDARY CIRCUITS WITH TELEPHONE AND/OR CABLE TV

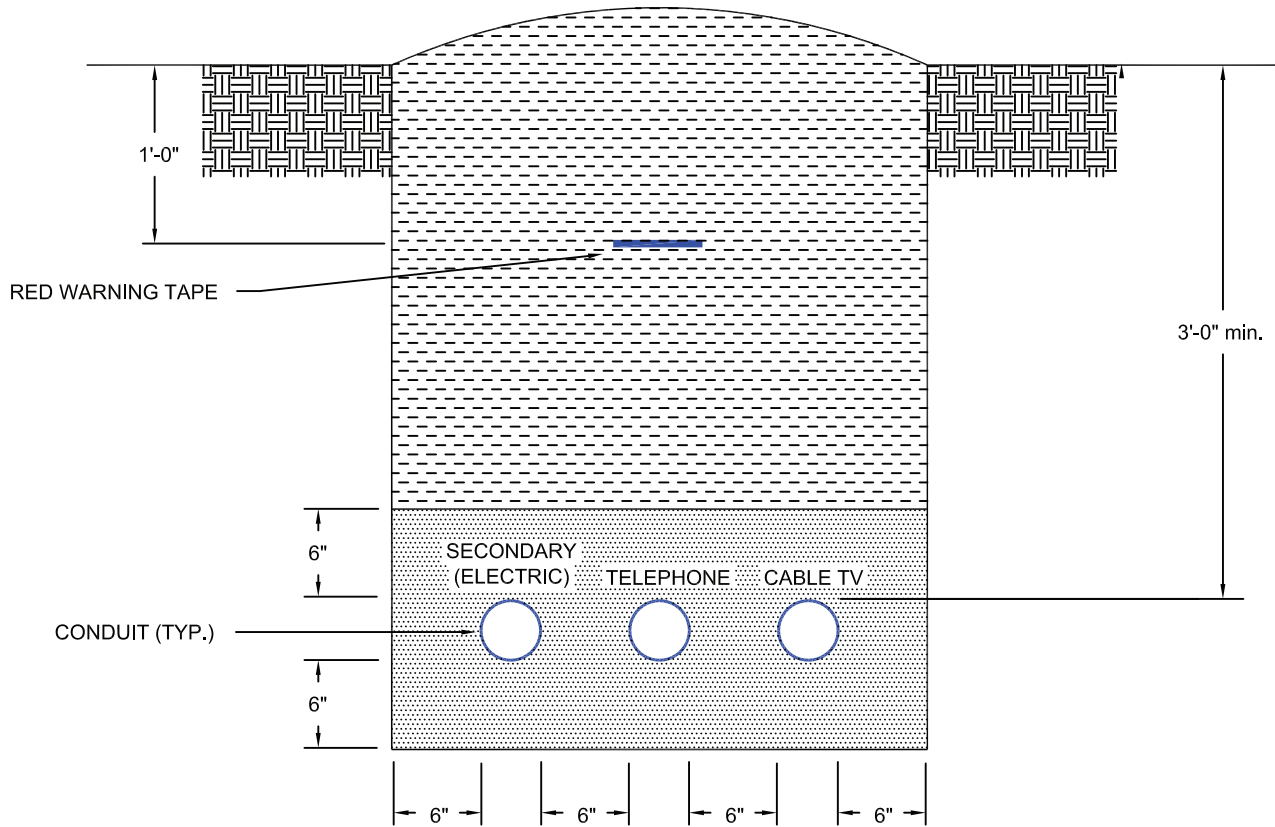

**NOTE:**

1. TRENCH WIDTH AS REQUIRED TO MAINTAIN 6" MINIMUM SPACING BETWEEN ALL CONDUITS AND TRENCH SIDEWALLS.
2. TRENCH TO BE INSPECTED BY A REPRESENTATIVE OF NHEC PRIOR TO BACKFILLING.



WHEEL COMPACTED BACKFILL,  
NO ROCKS LARGER THAN 6"  
DIAMETER



SAND OR FINE BACKFILL,  
NO ROCKS LARGER THAN 1"  
DIAMETER



UNDISTURBED EARTH



**CONSTRUCTION STANDARDS**  
TRENCH FOR JOINT ELECTRIC  
AND COMMUNICATION FACILITIES

IU Secondary Trench

ISSUE DATE: 06/05

# CONCRETE CAPPED TRENCH

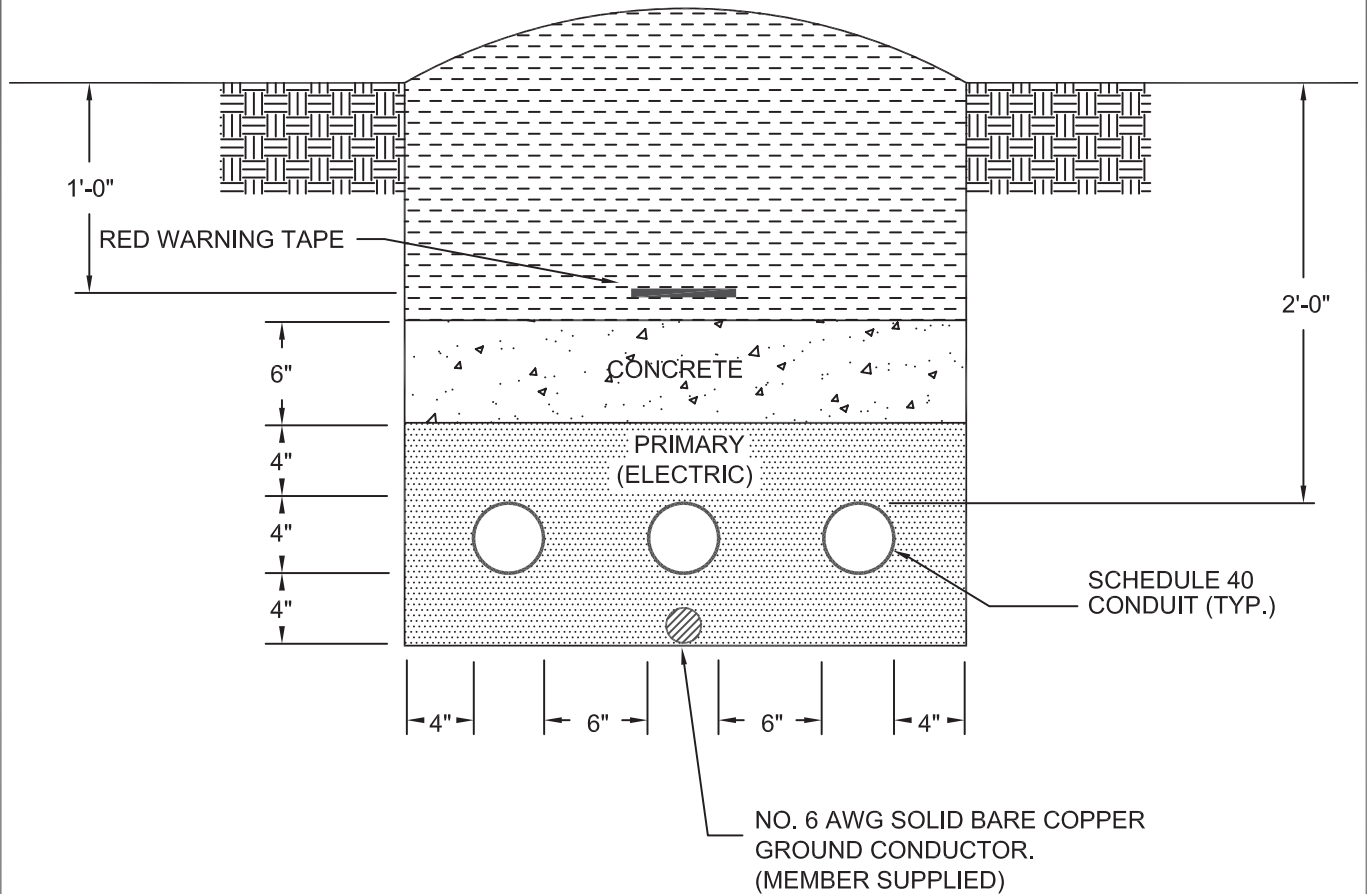

**NOTE:**

1. TRENCH WIDTH AS REQUIRED TO MAINTAIN 6" MINIMUM SPACING BETWEEN ALL CONDUITS AND 4" TO TRENCH SIDEWALLS.
2. CONCRETE TO BE 5000 PSI
3. TRENCH TO BE INSPECTED BY A REPRESENTATIVE OF NHEC PRIOR TO BACKFILLING.

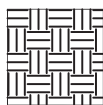

UNDISTURBED EARTH

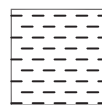

WHEEL COMPACTED BACKFILL,  
NO ROCKS LARGER THAN 4"  
DIAMETER

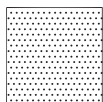

SAND OR FINE BACKFILL,  
NO ROCKS LARGER THAN 1"  
DIAMETER



5000 PSI CONCRETE ENCASEMENT

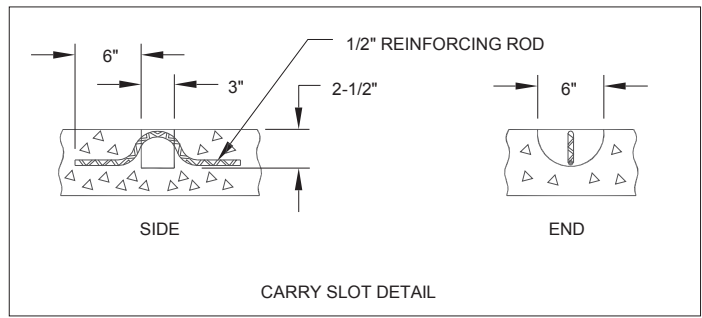
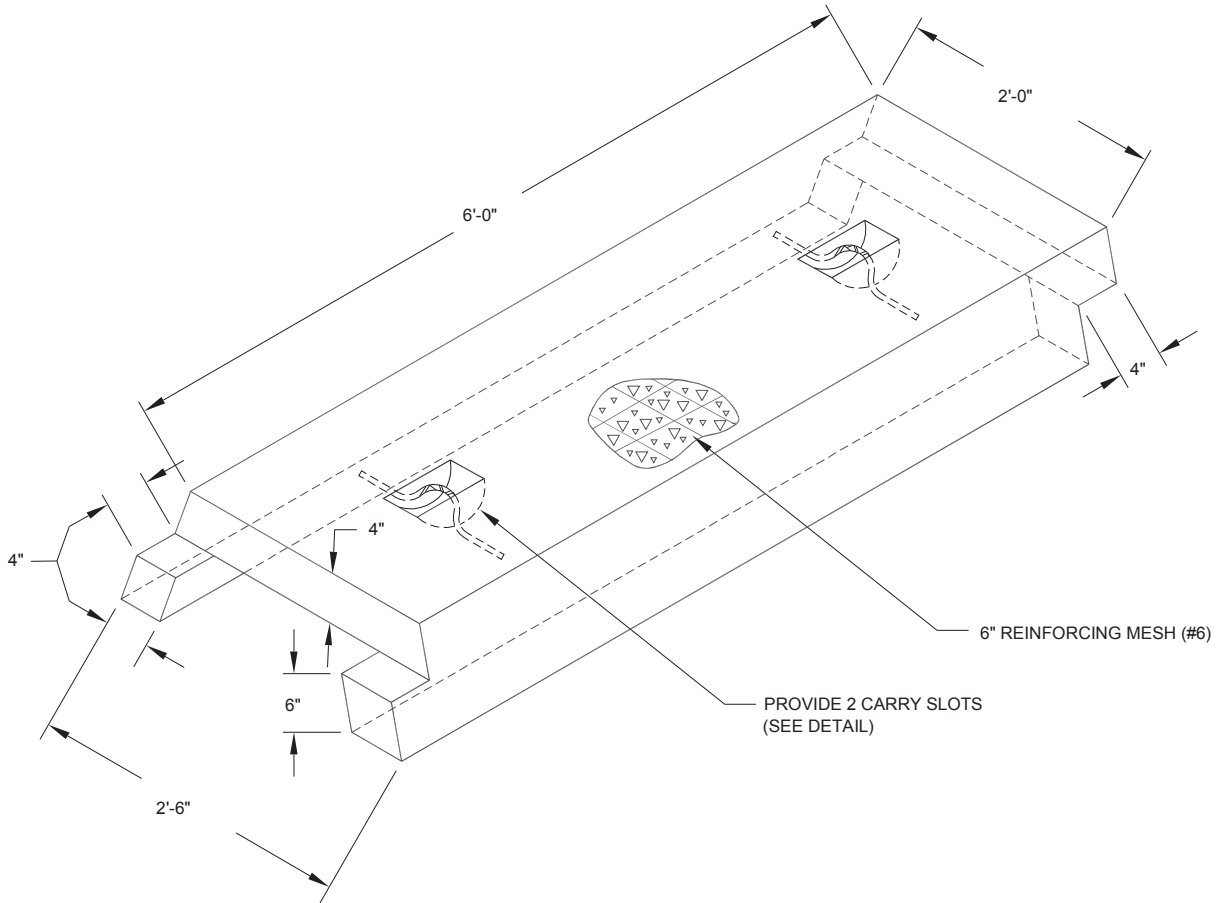

**NOTE:**

- 1.) CONCRETE SHALL HAVE A COMPRESSIVE STRENGTH OF 5000 P.S.I. AFTER 28 DAYS WHEN TESTED IN ACCORDANCE WITH ASTM C 39-72 (LATEST EDITION).



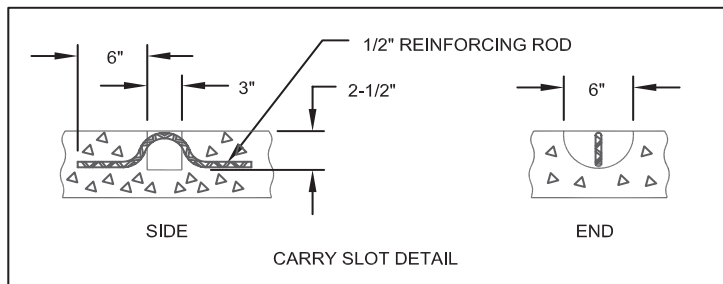
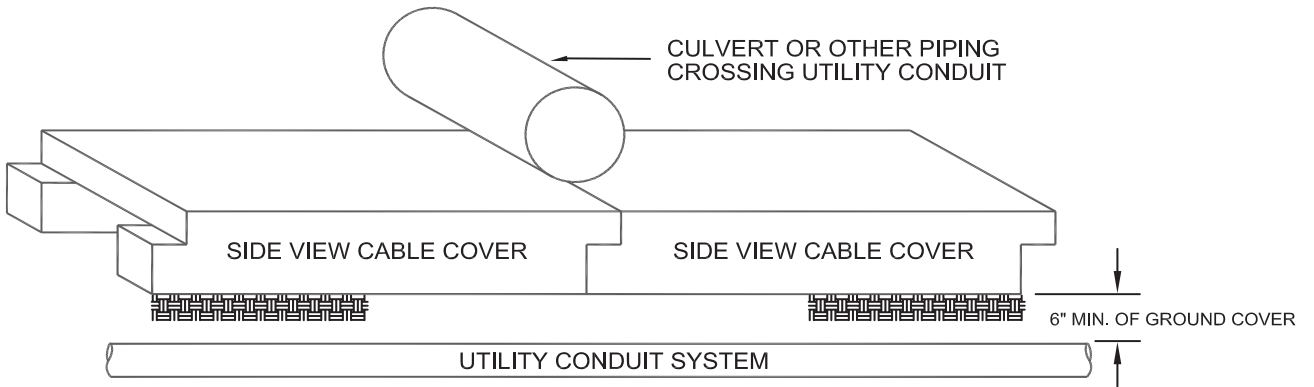
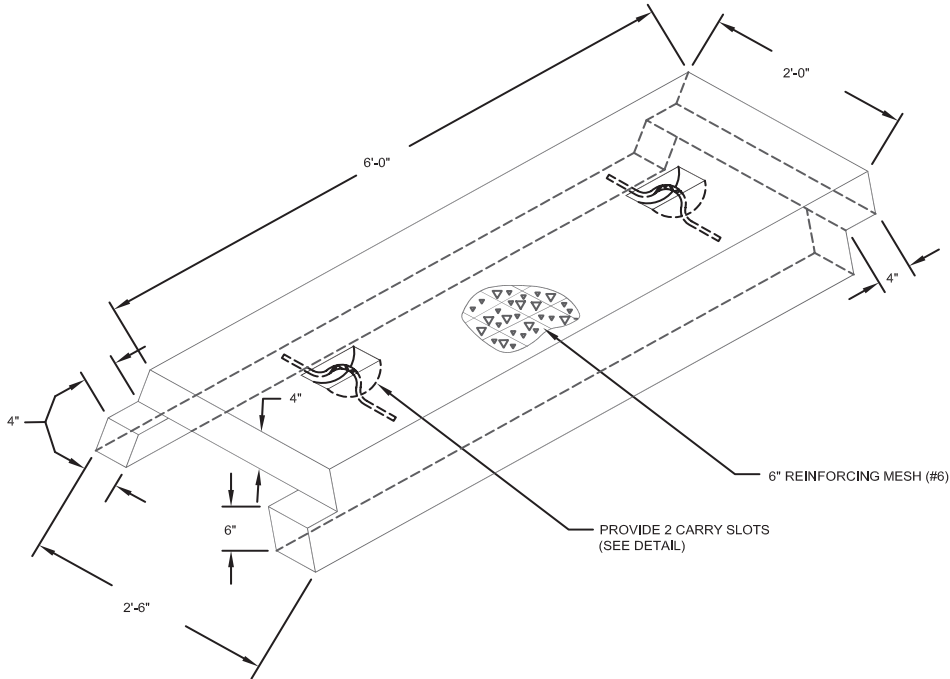

**NOTE:**

- 1.) CONCRETE SHALL HAVE A COMPRESSIVE STRENGTH OF 5000 P.S.I. AFTER 28 DAYS WHEN TESTED IN ACCORDANCE WITH ASTM C 39-72 (LATEST EDITION).



**CONSTRUCTION STANDARDS**

UNDERWATER CABLE COVER OR  
CULVERT CROSSING PROTECTOR

# Section 8: Glossary

---

## **Clearance**

A set distance between two objects.

## **Common Ground Point**

The conductor used to connect the grounding electrode to the equipment grounding conductor and/or to the grounded conductor of the circuit at the service.

## **Conduit**

A listed or approved pipe with a smooth interior surface to permit easy drawing-in of electrical conductors. A conduit may be metallic or non-metallic, depending on its usage, in accordance with codes and standards.

## **Corrosion Inhibitor**

Electrical joint compound used to retard oxidation of electrical connections.

## **Drip Loop**

A loop formed in overhead secondary conductors at the weatherhead, to prevent the entrance of water into the service entrance conduit and equipment.

## **Ground**

Connected to or in contact with earth or connected to some extended conductive body that serves instead of the earth.

## **Guy**

A cable or brace used to relieve the strain of overhead conductors on masts and poles.

## **Key box**

A permanently installed, locked box with keys enclosed, mounted on the outside of a building, for accessing the customer's premises to read, install, service or remove the utility's meters and/or electrical equipment during reasonable working hours.

## **Listed**

Equipment or material accepted by a nationally recognized testing laboratory, inspection agency, or other organization concerned with product evaluation.

## **Manual Circuit-Closing Block**

A provision for paralleling the meter circuit, allowing the meter to be removed without interrupting service to the member.

## **Meter Equipment**

Any equipment associated with measuring electric energy.

## **Meter Jaw**

A spring-loaded receptacle inside a meter socket which connects the terminals of a meter to the source or load conductors of the service.

## **Meter Socket**

The mounting device for socket type meters, consisting of meter jaws, connectors, an enclosure and in permanent installations an integrated main circuit breaker is required.

## **Mobile Home**

A house trailer serving as a permanent home.

## **Modular Home**

Also referred to as a manufactured home. A home designed with standardized units or dimensions and manufactured in a factory type facility.

## **Municipal, State Inspector**

The qualified representative of a city or the state, authorized to inspect electrical service installations on their behalf.

## **NEC**

National Electrical Code. Safety provisions for the installation of electrical equipment and conductors in buildings and other structures, published by the National Fire Protection Association.

## **NEMA**

National Electrical Manufacturers Association. A trade association which publishes standards for manufacturers of electrical equipment, including enclosures and racks.

## **NESC**

National Electrical Safety Code. Safety provisions for the installation, operation, and maintenance of electric supply and communication lines, published by Institute of Electrical and Electronics Engineers.

## **Neutral**

The grounded conductor in a single-phase, three-wire or three-phase or three-phase, four wire system. The service conductor at zero potential to ground.